

Apprenticeship Opportunity

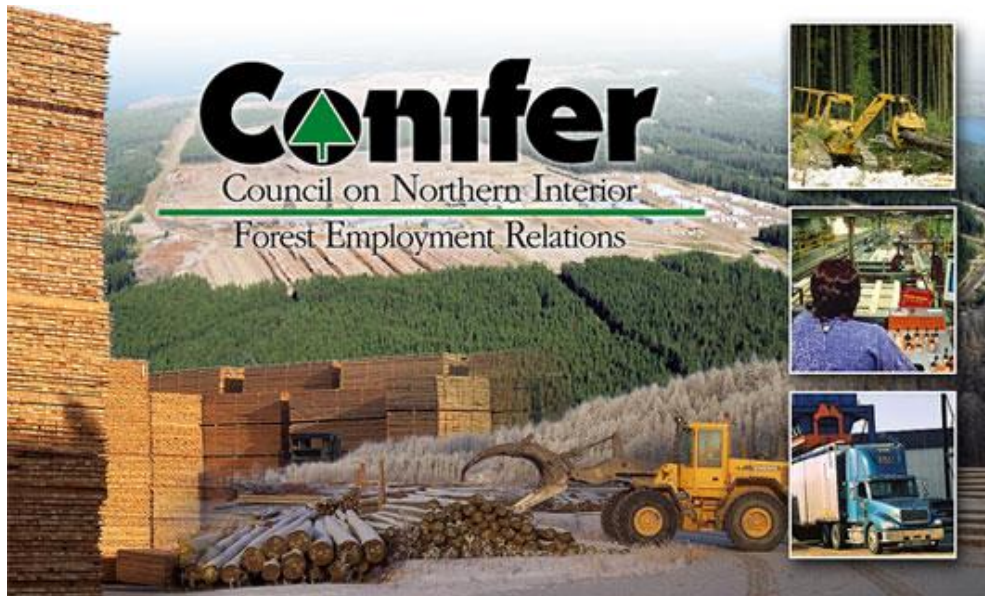

Candidate Preparation Package

Revised August 2013

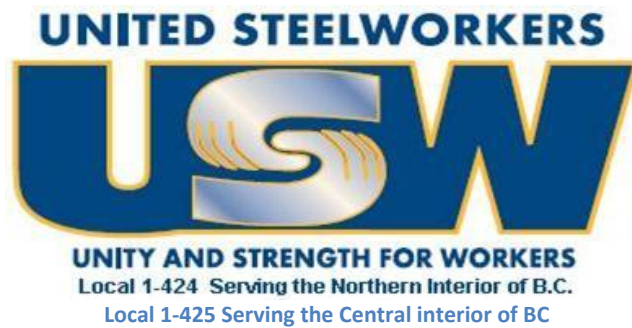



Table of Contents

SECTION 1: PREPARING FOR THE TESTS	5
 HOW TO STUDY FOR THE TESTS	5
DESCRIPTIONS OF THE TESTS	6
STEP 1: GET INFORMATION -- WHAT ARE THE BATTERY OF TESTS	6
STEP 2: HOW TO CONQUER TEST ANXIETY	7
STEP 3. MAKE A PLAN	8
STEP 4: MANAGE YOUR TIME	9
STEP 5: REVIEW THE BASICS	9
STEP 6: COMPLETE THE PRACTICE TESTS	9
DEVELOP A STUDY PLAN	10
WRITING MULTIPLE CHOICE TESTS	11
STRATEGIES ON ANSWERING MULTIPLE CHOICE QUESTIONS	11
SECTION 2: REVIEWING THE BASICS	12
SECTION 2: GENERAL PROBLEM SOLVING ABILITY	41
SECTION 3: MECHANICAL REASONING	45
SECTION 4: DETAIL CHECKING ABILITY	48
DETAIL CHECKING ABILITY	49
SECTION 5: ARITHMETIC ABILITY	50
SECTION 6: JUDGMENT AND COMPREHENSION	53
SECTION 7: SPATIAL REASONING (MECHANICAL TRADES ONLY)	58
SECTION 8: SPATIAL REASONING – FINE MOTOR COORDINATION AND WORKING WITH PATTERNS (ELECTRICAL TRADES ONLY)	60
SECTION 9: REASONING AND MATHEMATICAL SYMBOLS (ELECTRICAL TRADES ONLY)	62

SECTION 10: ANSWER KEYS	65
ANSWER KEY FOR SECTION: GENERAL PROBLEM SOLVING ABILITY	66
ANSWER KEY FOR SECTION: MECHANICAL REASONING	67
ANSWER KEY FOR SECTION: DETAIL CHECKING ABILITY	69
ANSWER KEY FOR SECTION: ARITHMETIC REASONING	70
ANSWER KEY FOR SECTION: JUDGMENT & COMPREHENSION TEST	71
ANSWER KEY FOR SECTION: SPATIAL REASONING (MECHANICAL TRADES ONLY)	73
ANSWER KEY FOR SECTION: REASONING USING MATHEMATICAL SYMBOLS (ELECTRICAL TRADES ONLY)	74



Introduction to the Candidate Preparation Package

For each of the tests in the Self-Evaluation test series, instructions and supportive information have been drafted which will assist in the practices tests, **please read the instructions carefully.** The practices tests are very similar to the actual conditions you would encounter in the actual testing situation. In working through each individual test, you are encouraged to read the test directions over carefully, and then work through the actual self-evaluation questions either timing yourself, or ask someone else to time you. Your timing should be exact since a few seconds one way or another can make a difference as timing for the actual tests will be precise.



When you have completed a section, go to the appropriate answer key and check your answers. Compare your score to the standard scores given on the answer key (appendix 1). If your score is notably above the standard scores given on the answer key, you can have some confidence that you should be able to perform acceptable on the selection test series. **If you are very close to the standard score or below it, you should seek out assistance to enhance your skills in the areas of difficulty.** The objective of this self-evaluation study guide is to help prepare you for success and help identify any areas where you may want to improve on in pursuit of a career in the trades.

This CONIFER document has been revised by the staff at the Northern Skills Training Program. We have developed many supplementary materials that can be accessed to address your further preparation needs. Northern Skills Training can be contacted at 1-250-563-7712



Funding provided through the Canada British Columbia Labour Market Agreement

Terry Tate: NSTP program Coordinator, USW Local 1-424
Loran Dick, NST Training Specialist, M. Turner & Associates
Myrt Turner, NST Training Specialist, M. Turner & Associates

SECTION 1: PREPARING FOR THE TESTS



How to Study for the tests

Taking any test can be tough. But, don't let the written test scare you! If you prepare ahead of time, you can achieve a top score. First, the bad news: Getting ready for any test takes work! If you plan to enter an apprenticeship, you'll need to know how to answer questions in Shop Arithmetic, Tool Knowledge, Mechanical Insight, Rotated Blocks, Symbol Series, and Map Reading, to name a few. By honing in on these skills, you will take your first step toward achieving a career in the trades. However, there are all sorts of pitfalls that can prevent you from doing your best on tests. Here are some obstacles that can stand in the way of your success.

- Being unfamiliar with the format of the test
- Being paralyzed by test anxiety
- Leaving your preparation to the last minute
- Not preparing at all



Now the good news:

Using this preparation package and completing the practice tests puts *you* in control. In just six easy-to-follow steps, you will learn everything you need to know to make sure that *you* are in charge of your preparation and your performance on the test.

Here's how it works: Each step leads you through everything you need to know and do to get ready to master your tests. Each of the steps listed below gives you tips and activities to help you prepare for any test. These steps work! Follow them closely and your chances of success on the tests will be greatly increased.

Step 1. Get Information – know what the tests are and what you need to know

Step 2. Conquer Test Anxiety – controlling your test anxiety is a major step to passing the tests

Step 3. Make a Plan – Don't put it off. The sooner you plan for success, the sooner you will be successful

Step 4. Manage Your Time – an apprenticeship isn't a sprint, it's a marathon and you have to be prepared to do a little every day.

Step 5. Review the Basics

Step 6: Complete the practice tests

DESCRIPTIONS OF THE TESTS

Step 1: Get Information -- What are the battery of tests

There is a battery of tests as part of the apprenticeship application process. Each test is timed and each test has its own unique cut off score. Use the descriptors on the next few pages to identify your areas of weakness so that you are prepared to get the highest score possible on test day.

General Problem Solving Ability Test

This is a test of general problem solving ability. It contains various types of questions from the meaning of words, to calculations, to logical conclusions. There are 50 questions and you will have 12 minutes to answer as many as you can. It is very unlikely that you will finish the test but you will want to get as many right as possible.

Study Basic Math

Many of the questions on the General Problem Solving Ability test boil down to basic mathematics. Some of the questions involve simple math equations, while others are written as word problems. Luckily these math questions are fairly simple when you strip away all of the "flair" and unnecessary text. Many libraries have study guides for math, and if you look online you can find many different websites that have practice math quizzes that score your test immediately after you complete it.

Memory Exercises

Other questions are word problems that require you to decide which of three particular words are not like the other two. You can exercise your brain by doing basic memory exercises that help you quickly recognize which word is out of place, or in which sequence numbers or letters are supposed to go.

Practice Tests

Take practice tests. You can find practice tests online for just about any and every subject, many of them designed to check your answers immediately after you click "Finish." A few of these tests will even walk you through your incorrect answers to show you how to properly tackle the questions that you got wrong.

Assembly Test

The test for assembly and matching covers skill sets as: knowing the use of specific tools, assembling products, matching geometrical figures, as well as determining the knowledge of tools or machinery used in a given job.

Tables Test

This is a test of your detail checking ability and your ability to pick out requested/required information from a table.

Mechanical Comprehension Test

The *Mechanical Comprehension Test* is an assessment that measures an individual's aptitude to learn mechanical skills. The test has 68 multiple choice items that present simple, frequently encountered mechanisms and situations. While not based on specific training, the test does require a working knowledge of basic mechanical operations and the application of physical laws. It is a timed test to be completed in 30 minutes or less.

Arithmetic

This is a test of your ability to do numerical computations quickly and accurately – adding, subtracting, multiplying, and dividing. You will have 5 minutes for this test. You are not expected to be able to do all of the problems in the time limits given however you will want to work quickly and be as accurate as you can.

Patterns (electrical trades only)

This is a test of your ability to copy a given pattern accurately. You will have 5 minutes to complete the test. There are different tests, depending on whether you are going into the mechanical trades or electrical trades. The practice tests will identify which group the study guide is geared to.

Reasoning (electrical trades only)

This is a test of your ability to reason and express problems in simple form using conventional mathematical symbols. Your task is to read each problem and to formulate an answer for it. You are not expected to have time to finish all the problems so it is important to know how to manage your time to get the best score.

Industrial Reading Test

This is a test of your reading ability. After reading the given passages you are to choose the best answer to the questions given about the passage.

Step 2: How to conquer test anxiety

First of all, what is test anxiety? Anxiety is a general term for the body's response to nervousness, fear, apprehension, and worry. It is like a built-in smoke alarm. When there is a perceived danger, your body reacts. It's normal, everyone has it. It is normal to feel anxious before going on a roller-coaster ride, in a hot air balloon, before a job interview, and yes, before you take a test.

The main thing to remember about test anxiety is that it isn't going to go away but you can control it by being prepared, organized, and practicing for the tests.

Conquering your test anxiety

Cause: you are unfamiliar with the test

Solution: Take time to learn about the set of tests for either mechanical or electrical trades. There are a specific number of questions and a time limit. Each test has a specific format; multiple choice, constructed response.

Some people deal with their test anxiety by avoiding thinking about it until the last minute. They hope by not thinking about the test that the problem will miraculously be cured and they'll pass. **Don't Do That!!!!**

Cause: You haven't been to school in a long time or the subjects of the test are all new.

Solution: Now is the time to make a study plan and stick to it. These tests are not rocket science. A lot of it you already know but may have forgotten. You just need a refresher. Some of the material on the test will be new. That's ok. Take the time to learn the material. Most of it is common sense and with a bit of hard work you will be successful.

Cause: You have negative thoughts like...

- *I always do poorly on tests*
- *I'm going to flunk these tests*
- *Everyone will know I didn't pass and will think I'm a failure*
- *Everyone else is smarter than I am*

Solution:

When you hear yourself saying...

- I always do poorly on tests
- If I don't pass this time, I'm a failure
- The test is going to have trick questions
- There is so much to learn. I'll never know it all.

Be positive

- I've got a good plan and am working hard. I'll be prepared for this test
- I'm going to pass...I'm studying hard...but if I don't pass, I can bounce back
- The test is designed to let me show what I know, and I know all the formats of the tests
- I don't need to know the answer to every question. I just need to know enough to pass.

Step 3. Make a Plan

Your success starts with a plan of action. Making a plan is easy; sticking to the plan is the hard part. Your plan has to balance work, daily living, and studying.

Don't fall into the cram trap. Take control of your preparation time by mapping out a study schedule.

Even more important than making a plan is making a commitment. You can't review everything you need to know for a mechanical/spatial test in one night. You have to set aside some time every day for study and practice. Try for at least 20 minutes a day. Twenty minutes daily will do you much more good than two hours on Saturday.

Don't put off your study until the day before the test. Start now.

Step 4: Manage Your Time

Make the time to prepare. Whether you have 2 weeks or 2 months, you need to make sure your foundational skills are up to speed so that you can be successful.

Hopefully, you have at least one month to prepare. Make a study plan and put aside at least one hour per day to go over the basic principles, practice the tests in this guide, and determine where your strengths and weaknesses are.

In order to develop your techniques and complete sufficient practice papers to identify any weak areas you will need to spend between 30-60 minutes each day. You will then be able to take remedial action to address your weak areas.

If you think that this could be a problem then you are not alone. Very few people feel that they have a 'spare' hour a day just waiting to be filled. You will need to take positive action to schedule this task. The conditions in which you practice will need to be as near to the actual test conditions as possible. It is vital that the environment is free of distractions and interruptions.

Step 5: Review The Basics

When you go into the trades, having a solid foundation in essential skills, such as reading and comprehension, document use, and numeracy is critical for being good at what you do. Take the time to review the basics as well as refresh yourself in the basics of physics.

Reading: Make time, every day, to read something. Especially, if you are not a regular reader. Many people struggle with these tests due to the fact that they don't read on a regular basis. Read about something you enjoy, such as car magazines, hunting and fishing, or any other topic you are interested in.

Numeracy: Review the basics. Take some time to practice fractions and just adding, subtracting, multiplying, and dividing. You'll be surprised at how quickly everything comes back when you've been out of school for any length of time.

Physics and Mechanical Principles: Also, take the time to review basic principles. You will need to pick information out of **tables** and **use special reasoning to assemble pieces in a diagram**. If you have any questions or need any help, there is lots of information online. Just do a Google search and you'll find explanations on how things work.

Step 6: Complete the Practice Tests

Complete each of the practice tests, one at a time, and follow the instructions carefully. Use a stopwatch or have someone time you the first time through. This will give you an idea of where you are and what you need to work on (complete the plan.)

After you have checked your answers, go back and review the test. For each question, try and explain to yourself (or to someone else) why the right is right and why each wrong answer is wrong. This helps in understanding the concepts and principles.

Go over the practice tests a second time and work through each question so that you understand the concepts. If you don't understand, you can often find the answer online.

DEVELOP A STUDY PLAN

Step 1: Decide which topics you are good at and which ones give you difficulty. Use the chart below to rate how good you are on each topic

Step 2: Decide where to focus your studying and

Step 3: Make a study schedule that you will stick to.

- Mark a calendar with frequent 2 hour study sessions and write in the topics to cover for each session
- Avoid cramming all topics into one session
- Break up each session into four 30 minute periods, with 10 minute breaks
- Invite other people to study with you

9 is high and 1 is low circle one

Math Formulas	9	8	7	6	5	4	3	2	1
Mechanical Comprehension	9	8	7	6	5	4	3	2	1
Arithmetic (Basic Math)	9	8	7	6	5	4	3	2	1
Patterns (electrical Only)	9	8	7	6	5	4	3	2	1
Reading Text	9	8	7	6	5	4	3	2	1
Spatial Reasoning (electrical only)	9	8	7	6	5	4	3	2	1
Detail Checking	9	8	7	6	5	4	3	2	1
Using Tables	9	8	7	6	5	4	3	2	1
Judgment and Comprehension	9	8	7	6	5	4	3	2	1

Make a study plan in a format that works for you. Set a deadline for completing it!!!

Go back to the section “Descriptions of the Tests” to identify what needs to be on your study list.

WRITING MULTIPLE CHOICE TESTS

Multiple Choice questions ask you to:

- Answer a question
- Finish a sentence by choosing the correct missing information
- Match a word with a definition or vice versa
- Make a calculation
- Look at a diagram and identify something from it

Strategies on answering multiple choice questions

- Make sure that you understand what the question is asking
- Read the question carefully and select the best answer
- Often your first choice is the best one
- Don't keep changing your answers
- Break longer questions down into smaller bits to make them easier to understand
- Watch for words such as all, none, always and never in questions and answers
- Mark the questions you are unsure of and go on to the next question. Come back to it later if you have time
- Read all the possible answers before choosing your answer
- Cross off answers you know are wrong
- Check that you have marked your answers in the right place. Be really careful to answer in the right place when you skip questions
- Go back to the questions you were unsure of and make your best guess if you really don't know

SECTION 2: REVIEWING THE BASICS

Reading Strategies

The Value of Vocabulary Building

Words are unique and interesting. Having a strong vocabulary is especially important as you go into the trades. It gives you the right words to use at the right time. As technology rapidly changes the landscape of working in the trades, a strong vocabulary will give you a solid foundation for learning new things.

When you come across a word you don't know, look in the same sentence for words or phrases that are clues.

If you don't find clues in the same sentence, look for clues in the rest of the paragraph.

Guess the meaning of the word

Try to see if it makes sense

Word Relationships

Part of building your vocabulary is understanding the relationship between words. Words that mean the same thing but look different are called synonyms. Their meanings are very similar (e.g., pretty/cute). An antonym is a word that has the opposite meaning of another word (e.g., pretty/ugly). A homonym is a word that sounds like another word but has a different meaning (e.g., there/their).

Because these terms are often confused, here is an easy way to keep them straight.

Homonym ... Hears like

Synonym...Same

Antonym...An opposite

For example, the word “weak” can apply to a person or an object. The diagram on the next page gives an example of how synonyms, antonyms, and homonyms apply.

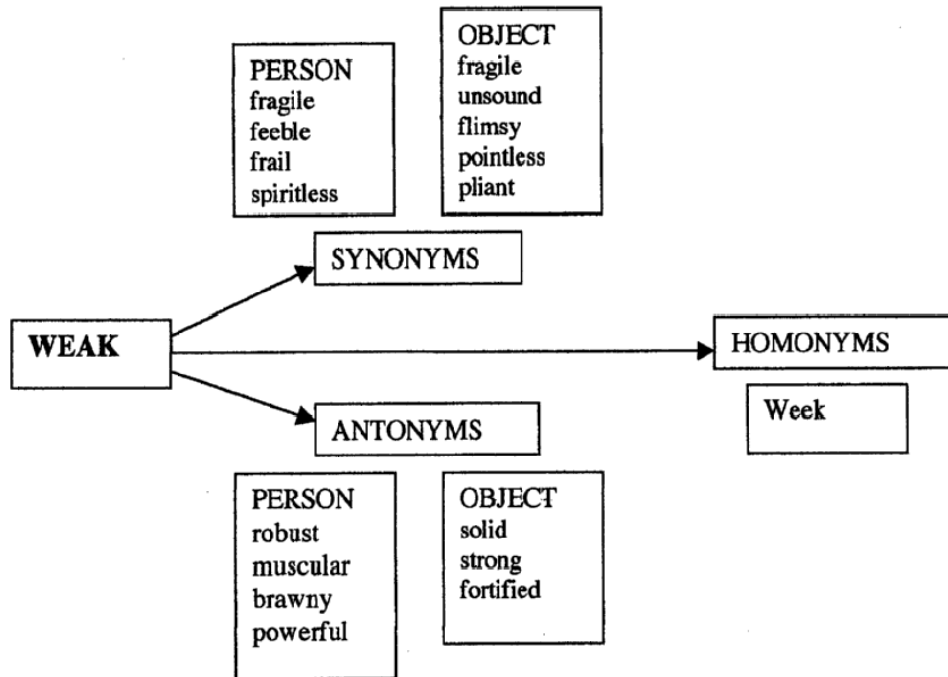

An analogy is an implied (unstated) relationship between two pairs of objects. Because the relationship is implied, the first thing you must decide is what kind of relationship exists between the pairs (i.e., synonym, antonym, homonym, time, place, age, etc.). Because analogies require you to identify similar relationships between dissimilar objects, understanding analogies is one of the highest levels of thinking. For example,

Up is to down as fast is to slow (antonym)

Context Clues

A key strategy in figuring out a meaning of a word is from its context. The context is the other words and sentences around the new word. When you figure out the meaning of a word from context, you are making a guess about what the word means. To do this, you use the hints and clues of the other words and sentences. You might not be able to guess the exact meaning of a word, but you may be close enough to get the meaning of the sentence it is in.

A basic strategy for unlocking the meaning of an unfamiliar word is to search the context of the sentence in which the new word appears for clues. Sometimes this can be easy to do because the author may have provided a definition or a synonym right next to or near a term that you can use to unlock its meaning.

For example, in the following sentence: “Don’t think of words as separate, discrete items or entities.” What is the meaning of the word “entities?” The definition is right there – separate, discrete items. But what is the meaning of discrete? The meaning of that word is right there as well – separate.

When in doubt about the meaning of an unfamiliar word, look around in the sentence; check to see if there is a definition or synonym clue to help you.

Another kind of context clue is a word or words of opposite meaning (antonym) set somewhere near a word that is unfamiliar. If you find a word or words of opposite meaning and you recognize it or them, you are home free.

For example, in the following sentence: “I was not exactly enamored of the travel plans my agent made for me; my lack of enthusiasm was triggered by the eight-hour layover required between flights.” What is the meaning of the word enamored? You can use the context of the sentence to reason in this way: Enamored means just the opposite of lacking in enthusiasm for.

So, here are two strategies to help you unlock words you may be unfamiliar with:

1. Check for synonyms or definitions embedded right in the words and sentences surrounding the word. If you find a synonym or definition, reread the sentence with the new term keeping that synonym or definition in mind.
2. Check for an antonym clue. If you find one, think about its meaning, actually telling yourself the opposite meaning. Then reread the sentence and rephrase it in your own mind.

There are several different skills areas that you need to develop that will increase your ability to read and comprehend text.

Choosing Main Ideas or Details

This requires skill at selecting the important information and supporting details from a written document. Looking for main ideas and details is a common reading task. But, as mentioned previously, reading texts encountered in the workplace differ from the selections most often used in reading programs. In such programs, the main idea is generally found in the topic sentence at the beginning of a paragraph or occasionally in a concluding sentence. However, written communication found in the workplace is often not constructed in such an organized manner. Consequently, the employee needs to be able to use clues other than placement to identify the main ideas and important details.

Understanding Word Meanings

Although some basic vocabulary is involved in this skill area, the emphasis is on using context to determine specific word meanings. The demands of the workplace progress from the need to know simple words and identify definitions clearly stated in the reading to the need to use the context to determine the meanings of more difficult words. Jargon, technical terminology, and words with multiple meanings are used increasingly as the contexts become more complex.

Applying Instructions

Conveying instructions is the principal purpose of a great deal of workplace communication. Skill in applying instructions involves sequencing and generalizing. As in the other skill areas, the workplace requirements range from the simple to the more complex. As the levels increase, the instructions contain more steps and conditionals are added. At the lower levels, employees need only apply instructions to clearly described situations; at the higher levels, employees must apply instructions to less similar and, eventually, to new situations.

Applying Information and Reasoning

Often, for effective performance of a task, it is necessary for employees to apply information given in workplace communications to similar or new situations, to predict consequences of certain actions, and to understand the reasoning, which may or may not be stated, behind a policy. As in the previous category, employees may be asked to apply information and reasoning to clearly described situations at the lower levels, while, at higher levels, they must apply information and reasoning to similar and then to new situations.

Reading for Information is the skill people use when they read and use written text in order to do a job. The written texts include memos, letters, directions, signs, notices, bulletins, policies, and regulations. It is often the case that workplace communications are not necessarily well-written or targeted to the appropriate audience. Reading for Information materials do not include information that is presented graphically, such as in charts, forms, or blueprints.

Reviewing The Basics

Mathematics Review

Here are some basic concepts of math that will help you on the tests.

Understanding Fractions

When we talk about fractions, we talk about PARTS OF THE WHOLE. Sometimes we have whole and fractional parts both. The WHOLE is always divided into equal parts.

For example:

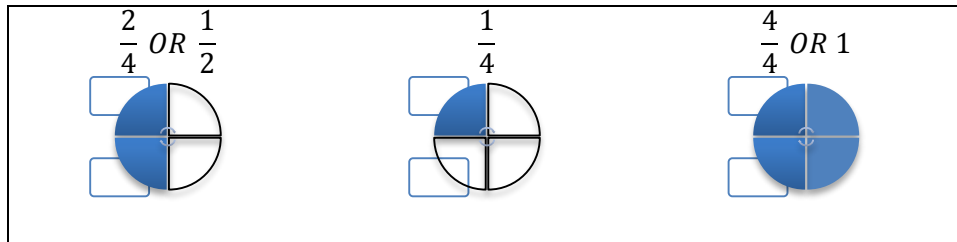

Rules for Fractions

Adding

1. Make the bottom numbers (denominator) the same
2. Add top numbers (numerator)
3. Simplify

Subtracting

1. Make the bottom numbers the same
2. Subtract the top numbers
3. Simplify

Multiplying

1. Multiply the top numbers
2. Multiply the bottom numbers
3. Simplify

Dividing

1. Turn the second fraction upside down
2. Follow the steps for multiplying
3. Simplify

Order of Operations

Problem: Solve the following math problem

$$3 + 4 \times 2$$

Solution:

Student 1	Student 2
$3 + 4 \times 2$	$3 + 4 \times 2$
$= 7 \times 2$	$= 3 + 8$
$= 14$	$= 11$

There can only be one right answer. Student 1 performed the addition first and then multiplied while student 2 multiplied first and then added. So, we need to have a set of rules to follow so that we only get one answer. This is known as the Order of Operations.

Rule 1: First perform any calculations inside parenthesis (brackets)

Rule 2: Next perform all multiplications and divisions, working from left to right

Rule 3: Last, perform all additions and subtractions, working from left to right.

In the above example, Student 2 has the right answer following Rules 2 and 3.

Here are some example of the Order of Operations:

Example 1: Evaluate $3 + 6 \times (5 + 4) \div 3 - 7$

Solution:

$$\begin{aligned} \text{Step 1: } & 3 + 6 \times (5 + 4) \div 3 - 7 = 3 + 6 \times 9 \div 3 - 7 && \text{(add inside brackets)} \\ \text{Step 2: } & 3 + 6 \times 9 \div 3 - 7 = 3 + 54 \div 3 - 7 && \text{(multiply)} \\ \text{Step 3: } & 3 + 54 \div 3 - 7 = 3 + 18 - 7 && \text{(divide)} \\ \text{Step 4: } & 3 + 18 - 7 = 21 - 7 && \text{(add)} \\ \text{Step 5: } & 21 - 7 = 14 && \text{(subtract)} \end{aligned}$$

Example 2: Evaluate $9 - 5 \div (8 - 3) \times 2 + 6$

Solution:

$$\begin{aligned} \text{Step 1: } & 9 - 5 \div (8 - 3) \times 2 + 6 = 9 - 5 \div 5 \times 2 + 6 && \text{(brackets)} \\ \text{Step 2: } & 9 - 5 \div 5 \times 2 + 6 = 9 - 1 \times 2 + 6 && \text{(divide)} \\ \text{Step 3: } & 9 - 1 \times 2 + 6 = 9 - 2 + 6 && \text{(multiply)} \\ \text{Step 4: } & 9 - 2 + 6 = 7 + 6 && \text{(subtract)} \\ \text{Step 5: } & 7 + 6 = 13 && \text{(add)} \end{aligned}$$

In examples 1 and 2, you will notice that multiplication and division were done from left to right according to Rule 2. Similarly, addition and subtraction were done from left to right according to Rule 3.

When two or more operations occur inside a set of brackets, these operations should be completed according to Rules 2 and 3 as well as shown in Example 3.

Example 3: Evaluate $150 \div (6 + 3 \times 8) - 5$

Solution:

Step 1: $150 \div (6 + 3 \times 8) - 5 = 150 \div (6 + 24) - 5$ (multiply in brackets)
 Step 2: $150 \div (6 + 24) - 5 = 150 \div 30 - 5$ (add in brackets)
 Step 3: $150 \div 30 - 5 = 5 - 5$ (divide)
 Step 4: $5 - 5 = 0$ (subtract)

Example 4: Evaluate the following

$$\frac{36 - 6}{12 + 3}$$

Solution: This problem includes a “fraction bar” which means we have to divide the numerator (what’s on top of the bar) by the denominator (what’s on the bottom). It may look confusing at first but these are easy when you know the special rule for problems like these – solve the top, then solve the bottom, and then divide the top by the bottom.

$$\frac{36 - 6}{12 + 3} = \frac{30}{15} = 30 \div 15 = 2$$

The easy way to find the solution to these types of problems is to treat the top and the bottom as separate problems, use the rules of the order of operations, and then solve the top divided by the bottom.

Algebra: Solving for Variables

What is Algebra? For many, it is a scary term that when you hear it, you want to run screaming into another room. But in actual fact, algebra is just a term we use for the “language of math.” It’s not scary and in fact we use it on a daily basis – all of us. They just didn’t tell us that in school as if it was only for the “smart” kids.

What do I mean by using it every day? Well, let’s take a look at going to the grocery store. You want to buy a can of beans. In the beans aisle, you look at the price and find that they cost \$1.39. You decide to buy two. Up at the cash register, the cashier scans the cans of beans and finds that it comes to \$2.78. In the language of math (that’s algebra) we would say:

Reviewing The Basics

1 can of beans = \$1.39 and

2 cans of beans = 2 times \$1.39 which equals \$2.78 or $2 \times \$1.39 = \2.78

Here, we have described the purchase of beans in mathematical terms.

Now, one of the things we use math for is solving problems. The three basic kinds of problems are “What is...”, “what if...”, and “how many or how much.” For example:

- What is the area of the flooring in square feet?
- What if we had \$10? How many cans of beans could we buy?
- How much would 10 square meters of carpeting cost if the cost of the carpet is \$3.00 for each square meter purchased?

In order to solve these problems, we need to know some things and in math, we are given formulas to make it easy. For example, the formula for finding the area of a rectangle is the length times the width. In mathematical terms we would say...

$$\text{Area} = \text{Length} \times \text{width}$$

A variable is another word for something in math we don't know. And to represent what we don't know, we use a letter. For example, in the formula above, there are 3 things we don't know so we could apply 3 different letters to represent the formula:

$$A = l \times w$$

Where $A = \text{Area}$

$L = \text{length}$

$W = \text{width}$

To solve a problem about area, we need to find the answer to 2 of the 3 “unknowns” also known as variables (because they can be any number we choose). We go to the room, measure the length, measure the width, put those numbers into the equation and solve for the area. If the measured length is 12 feet, we would say:

$$L = 12 \text{ ft}$$

When we measure the width, it is 10 feet. We would say:

$$W = 10 \text{ ft}$$

So, the area of the room would be:

$$\text{Area} = 12 \text{ ft} \times 10 \text{ ft which equals } 120 \text{ square feet}$$

So, variables are letters that represent an unknown number. You must solve for that unknown number in single variable problems. To solve a problem with one variable (or one unknown) you must first isolate that variable (get it by itself) on one side of the equals sign.

An important rule to remember about equations (an equation is when you have an equals sign) is that anything that is done to one side of the equals sign must be done to the other to keep it equal. Think of the equals sign like a balance...if you have 10 pounds of something on one side, you must have 10 pounds of something on the other to stay in balance. If you add 5 pounds to one side, you must add 5 pounds to the other side to keep it in balance.

The main thing to remember is that you can do anything to one side of an equation as long as you do it to the other.

Example: Solve for x in the equation $2x + 3 = 5$.

Answer:

First you want to get the “ $2x$ ” isolated by itself on one side.

To do that, first get rid of the 3. Subtract 3 from both sides of the equation:

$$2x + 3 - 3 = 5 - 3$$

$$2x = 2.$$

Now since the x is being multiplied by the 2 in “ $2x$ ”, you must divide by 2 to get rid of it. So, divide both sides by 2

$$\frac{2x}{2} = \frac{2}{2} \text{ You can see that the 2 over 2 = 1. We have isolated } x \text{ and we can solve the equation.}$$

$$x = 1.$$

Here are some rules to remember when solving equations with variables:

- Variables can be added: $15x + 2x = 17x$
- Variables can be subtracted: $15x - 2x = 13x$
- Variables can be multiplied: $3x \times 2 = 6x$
- Variables can be divided: $6x \div 2 = 3x$
- A variable multiplied by itself is the variable squared: $x \times x = x^2$
- A variable divided by itself equals one: $\frac{x}{x} = 1$

Here are some examples:

Solve for x: $15x + 2x = 34$

Solution:

Step 1: Add the x's $17x = 34$

Step 2: Divide both side by 17 $\frac{17x}{17} = \frac{34}{17}$

Step 3: Solve both sides of the equals sign $x = 2$

Solve for x: $4x \times 6 + 2 = 26$

Solution:

Step 1: Follow order of operations – multiply first $4x \times 6 = 24x$

$$24x + 2 = 26$$

Step 2: Isolate the x by subtracting 2 from each side

$$24x + 2 - 2 = 26 - 2$$

$$24x = 24$$

Step 3: Solve for x by dividing both sides by 24

$$\frac{24x}{24} = \frac{24}{24}$$

$$x = 1$$

Example: Solve $5x - 24 = 3x + 12$

Solution:

Step 1: We need to get the x's on one side of the equation so we subtract 3x from both sides

$$5x - 3x - 24 = 3x - 3x + 12$$

$$2x - 24 = 12$$

Step 2: we can add 24 to each side to isolate 2x

$$2x - 24 + 24 = 12 + 24$$

$$2x = 36$$

Step 3: Divide both sides by 2

$$\frac{2x}{2} = \frac{36}{2}$$

$$x = 18$$

Positive/Negative Numbers

Positive and negative numbers can be confusing but if you keep a couple of images in your head, you will always get it right. Think about your bank account. If you add money to it, it keeps on increasing and if you take money out, it decreases; in other words you subtract money from the account. Now, think about having a line of credit on your bank account. It means that you can take out more money than you have it goes past zero into negative numbers. The negative number is the amount you now owe the bank. Now, think of adding and subtracting. Adding always moves in one direction and subtracting always moves in the opposite direction.

Reviewing The Basics

If you have \$10 in your account and deposit (add) \$10 you now have \$20. If you have \$5 in the account and take out \$10 (subtract) you now owe \$5 and your current balance is negative \$5 or -5. If you have a negative \$20 in your account and deposit \$30 you have a positive \$10 in your account.

Another way to look at it is on a number line.

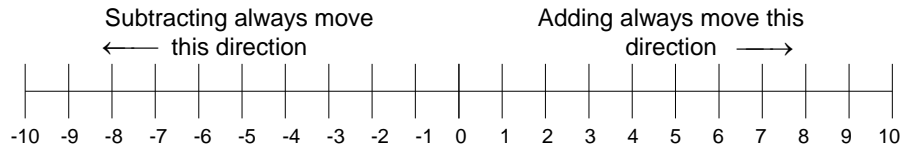

So, when adding or subtracting positive and negative numbers, find the first number on the line and then move in the direction of positive or negative.

For example: $-3 + 2 = -1$

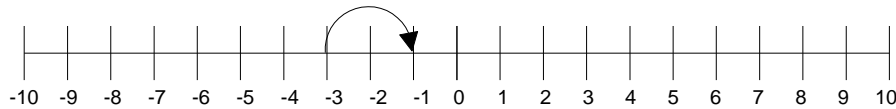

And $-3 - 2 = -5$



Rules for working with Positive / Negative Numbers

1. Adding Rules:

Positive + Positive = Positive: $5 + 4 = 9$

Negative + Negative = Negative: $(-7) + (-2) = -9$

Sum of a negative and a positive number: Use the sign of the larger number and subtract

$$(-7) + 4 = -3$$

$$6 + (-9) = -3$$

$$(-3) + 7 = 4$$

$$5 + (-3) = 2$$

Reviewing The Basics

2. Subtracting Rules:

Negative - Positive = Negative: $(-5) - 3 = -5 + (-3) = -8$

Positive - Negative = Positive + Positive = Positive: $5 - (-3) = 5 + 3 = 8$

Negative - Negative = Negative + Positive = Use the sign of the larger number and subtract (*Change double negatives to a positive*)

$(-5) - (-3) = (-5) + 3 = -2$

$(-3) - (-5) = (-3) + 5 = 2$

3. Multiplying Rules:

Positive x Positive = Positive: $3 \times 2 = 6$

Negative x Negative = Positive: $(-2) \times (-8) = 16$

Negative x Positive = Negative: $(-3) \times 4 = -12$

Positive x Negative = Negative: $3 \times (-4) = -12$

4. Dividing Rules:

Positive ÷ Positive = Positive: $12 \div 3 = 4$

Negative ÷ Negative = Positive: $(-12) \div (-3) = 4$

Negative ÷ Positive = Negative: $(-12) \div 3 = -4$

Positive ÷ Negative = Negative: $12 \div (-3) = -4$

Exponents

Exponents are sometimes referred to as powers and means the number of times the 'base' is being multiplied. In the study of algebra, exponents are used frequently. In the example to the right, one would say: Four to the power of 2 or four raised to the second power or four to the second. This would mean 4×4 or $(4) (4)$ or $4 \cdot 4$. Simplified the example would be 16.

If the power/exponent of a number is 1, the number will always equal itself. In other words, in our example if the exponent 2 was a 1, simplified the example would then be 4.

Exponent Rules

When working with exponents there are certain rules you'll need to remember.

When you are *multiplying* terms with the same base you can add the exponents.

$$4^2 \times 4^5 = 4^7$$

This means: $4 \times 4 \times 4 \times 4 \times 4 \times 4 \times 4$

When you are *dividing* terms with the same base you can subtract the exponents.

$$4^5 \div 4^2 = 4^3$$

This means: $4 \times 4 \times 4$

When *parentheses are* involved - you multiply $(8^3)^2 = 8^6$

$$y^a y^b = y^{(a+b)}$$

$$y^a x^a = (yx)^a$$

Squared and Cubed and 0's

When you multiply a number by itself it is referred to as being 'squared'. 4^2 is the same as saying "4 squared" which is equal to 16. If you multiply $4 \times 4 \times 4$ which is 4^3 it is called 4 cubed. Squaring is raising to the second power, cubing is raising to the third power. Raising something to a 1 means nothing at all, the base term remains the same. Now for the part that doesn't seem logical. When you raise a base to the power of 0, it equals 1. Any number raised to the power 0 equals 1 and 0 raised to any exponent or power is 0!

Decimal Exponents (aka Scientific Notation)

Scientific notation is the way we easily handle very large numbers or very small numbers. For example, instead of writing 0.0000000056, we write 5.6×10^{-9} . So, how does this work?

We can think of 5.6×10^{-9} as the product of two numbers: 5.6 (the digit term) and 10^{-9} (the exponent term).

Here are some examples of scientific notation.

$10000 = 1 \times 10^4$	$24327 = 2.4327 \times 10^4$
$1000 = 1 \times 10^3$	$7354 = 7.354 \times 10^3$
$100 = 1 \times 10^2$	$482 = 4.82 \times 10^2$
$10 = 1 \times 10^1$	$89 = 8.9 \times 10^1$ (not usually done)
$1 = 10^0$	
$1/10 = 0.1 = 1 \times 10^{-1}$	$0.32 = 3.2 \times 10^{-1}$ (not usually done)
$1/100 = 0.01 = 1 \times 10^{-2}$	$0.053 = 5.3 \times 10^{-2}$
$1/1000 = 0.001 = 1 \times 10^{-3}$	$0.0078 = 7.8 \times 10^{-3}$
$1/10000 = 0.0001 = 1 \times 10^{-4}$	$0.00044 = 4.4 \times 10^{-4}$

As you can see, the exponent of 10 is the number of places the decimal point must be shifted to give the number in long form. A **positive** exponent shows that the decimal point is shifted that number of places to the right. A **negative** exponent shows that the decimal point is shifted that number of places to the left.

In scientific notation, the digit term indicates the number of significant figures in the number. The exponential term only places the decimal point. As an example,

$$46600000 = 4.66 \times 10^7$$

This number only has 3 significant figures. The zeros are not significant; they are only holding a place. As another example,

$$0.00053 = 5.3 \times 10^{-4}$$

This number has 2 significant figures. The zeros are only place holders.

How to do calculations:

Scientific calculations are frequently handled by expressing quantities in scientific notation. Such operations require simple manipulation of exponents, usually exponents of 10. When the same base is used (e.g. 10), the following rules apply:

When the operation involves multiplication, add the exponents algebraically.

$$\text{example: } 10^3 \times 10^4 = 10^{(3+4)} = 10^7$$

$$\text{example: } 10^5 \times 10^2 \times 10^{-3} = 10^{(5+2+(-3))} = 10^4$$

When the operation involves division, subtract the divisor exponent from the numerator exponent.

$$\text{example: } 10^5/10^3 = 10^{(5-3)} = 10^2$$

$$\text{example: } 10^7/10^{12} = 10^{(7-12)} = 10^{-5}$$

$$\text{example: } 10^8/10^{-3} = 10^{(8-(-3))} = 10^{11}$$

$$\text{Example: } (10^6 \times 10^4)/(10^3 \times 10^2) = 10^{(6+4-(3+2))} = 10^5$$

When the operation involves powers or roots, multiply the exponent by the power number or divide the exponent by the power number, respectively.

example: $(10^5)^3 = 10(5 \times 3) = 10^{15}$

example: $(10^{-7})^4 = 10(-7 \times 4) = 10^{-28}$

example: $\sqrt{10^4} = (10^4)^{1/2} = 10(4 \times 1/2) = 10^2$

example: $\sqrt[5]{10^{20}} = (10^{20})^{1/5} = 10(20 \times 1/5) = 10^4$

Addition and Subtraction:

All numbers are converted to the same power of 10, and the digit terms are added or subtracted.

Example: $(4.215 \times 10^{-2}) + (3.2 \times 10^{-4}) = (4.215 \times 10^{-2}) + (0.032 \times 10^{-2}) = 4.247 \times 10^{-2}$

Example: $(8.97 \times 10^4) - (2.62 \times 10^3) = (8.97 \times 10^4) - (0.262 \times 10^4) = 8.71 \times 10^4$

Multiplication:

The digit terms are multiplied in the normal way and the exponents are added. The end result is changed so that there is only one nonzero digit to the left of the decimal.

Example: $(3.4 \times 10^6)(4.2 \times 10^3) = (3.4)(4.2) \times 10(6+3) = 14.28 \times 10^9 = 1.4 \times 10^{10}$

(to 2 significant figures)

Example: $(6.73 \times 10^{-5})(2.91 \times 10^2) = (6.73)(2.91) \times 10(-5+2) = 19.58 \times 10^{-3} = 1.96 \times 10^{-2}$

(to 3 significant figures)

Division:

The digit terms are divided in the normal way and the exponents are subtracted. The quotient is changed (if necessary) so that there is only one nonzero digit to the left of the decimal.

Example: $(6.4 \times 10^6)/(8.9 \times 10^2) = (6.4)/(8.9) \times 10(6-2) = 0.719 \times 10^4 = 7.2 \times 10^3$

(to 2 significant figures)

Example: $(3.2 \times 10^3)/(5.7 \times 10^{-2}) = (3.2)/(5.7) \times 10^{3-(-2)} = 0.561 \times 10^5 = 5.6 \times 10^4$ (to 2

significant figures)

Powers of Exponentials:

The digit term is raised to the indicated power and the exponent is multiplied by the number that indicates the power.

Example: $(2.4 \times 10^4)^3 = (2.4)^3 \times 10(4 \times 3) = 13.824 \times 10^{12} = 1.4 \times 10^{13}$

(to 2 significant figures)

Example: $(6.53 \times 10^{-3})^2 = (6.53)^2 \times 10(-3) \times 2 = 42.64 \times 10^{-6} = 4.26 \times 10^{-5}$

(to 3 significant figures)

Roots of Exponentials:

Change the exponent if necessary so that the number is divisible by the root. Remember that taking the square root is the same as raising the number to the one-half power.

Example:

$$\sqrt{3.6 \times 10^5} = \sqrt{36 \times 10^4} = \sqrt{36} \times \sqrt{10^4} = 6.0 \times 10^2$$

Example:

$$\sqrt[3]{2.7 \times 10^{-8}} = \sqrt[3]{27 \times 10^{-9}} = \sqrt[3]{27} \times \sqrt[3]{10^{-9}} = 3 \times 10^{-3}$$

Overview of Mechanical Reasoning Tests

These tests are designed to assess your knowledge of physical and mechanical principles. Questions are in the form of a question and a diagram and you will need to determine which mechanical principle is being illustrated. No specialist knowledge is required to answer these questions, only an understanding of basic mechanical and physical principles.

Mechanical Reasoning Tests measure your knowledge of:

- Levers
- Pulleys
- Gears
- Springs
- Gravity
- Electricity
- Magnetism
- Linear Force
- Centrifugal Force
- Centripetal Force
- Compression
- Expansion

Levers

A lever consists of a bar which pivots at a fixed point known as the fulcrum. In the example shown the fulcrum is at the center of the lever. This lever provides no mechanical advantage and the force needed to lift the weight is equal to the weight itself. However, if you want to lift a weight that is heavier than the force applied you can move the fulcrum closer to the weight to be lifted. This affects the force required in the following way:

$$w \times d1 = f \times d2$$

Where:

W = weight

d1 = distance from fulcrum to weight

f = force needed

d2 = distance from fulcrum to point where force is applied



Reviewing The Basics

In this example the fulcrum has been moved towards the weight so that the weight is 1 meter from the fulcrum. This means that the force can now be applied 2 meters from the fulcrum.

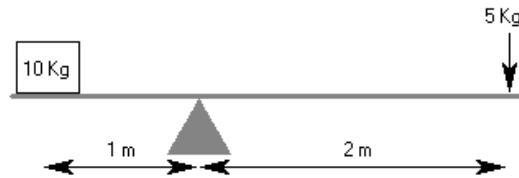

If you needed to calculate the force needed to lift the weight then you can rearrange the formula.

$$w \times d1 = f \times d2 \text{ can be rearranged to } f = (w \times d1)/d2$$

$$f = (10 \times 1)/2 \text{ (10/2 is the same as 5/1, the force required is 5 Kg)}$$

Example Questions

1. How much force is required to lift the weight?

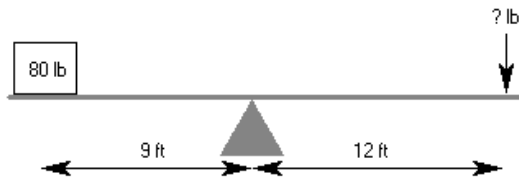

- A) 40lbs B) 50lbs C) 60lbs D) 70lbs

Answer

C - 60lbs is needed to lift the weight. It can be calculated like this:

$$f = (w \times d1)/d2 \quad f = (80 \times 9)/12 \quad f = (720)/12 \quad f = 60 \text{ lbs}$$

In practice, levers are used to reduce the force needed to move an object, in other words to make the task easier. However, in mechanical aptitude questions it is possible that you will see questions where the fulcrum has been placed closer to the force than the weight. This will mean that a force greater than the weight will be required to lift it.

You may see more complex questions involving levers, for example, there may be more than one weight. In this case you need to work out the force required to lift each weight independently and then add them together to get the total force required.

2. How much force is required to lift the weights?

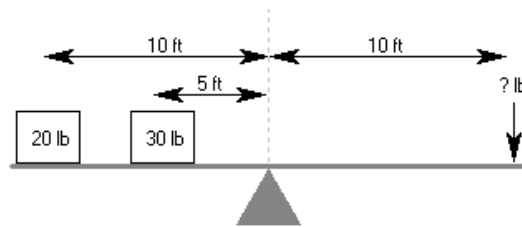

- A) 25lbs B) 35lbs C) 40lbs D) 45lbs

Answer

2. B - 35lbs is needed to lift the weight. It can be calculated like this:

$$f = (w_1 \times d_1) + (w_2 \times d_2) / d_3 \quad f = (20 \times 10) + (30 \times 5) / 10$$

$$f = (200 + 150) / 10$$

$$f = 35 \text{ lbs}$$

Pulleys

The pulleys used in this type of question consist of a grooved wheel and a block which holds it. A rope runs in the groove around the wheel and one end will be attached to either: a weight, a fixed object like the ceiling or to another pulley. For the purposes of these questions you can ignore the effect of friction.

Single Pulley

3. Which weight requires the least force to move?

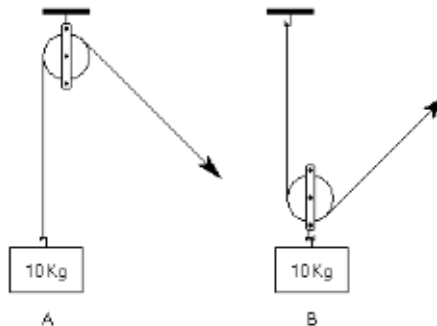

- A) A B) B C) Both require the same force

Answer

3. **B** – Weight B requires a force equal to 5 Kg whereas A requires a force equal to 10 Kg.

Single pulley questions are relatively straightforward. If the pulley is fixed, then the force required is equal to the weight. If the pulley moves with the weight then the force is equal to half of the weight. Another way of thinking about this is to divide the weight by the number of sections of rope supporting it to obtain the force needed to lift it. In A there is only one section of rope supporting the weight, so $10/1 = 10$ Kg required to lift the weight. In B there are two sections of rope supporting the weight, so $10/2 = 5$ Kg required to lift it.

Double Pulleys

There are two possible ways that two pulleys can be used. Either one pulley can be attached to the weight or neither of them can be.

4. Which weight requires the least force to move?

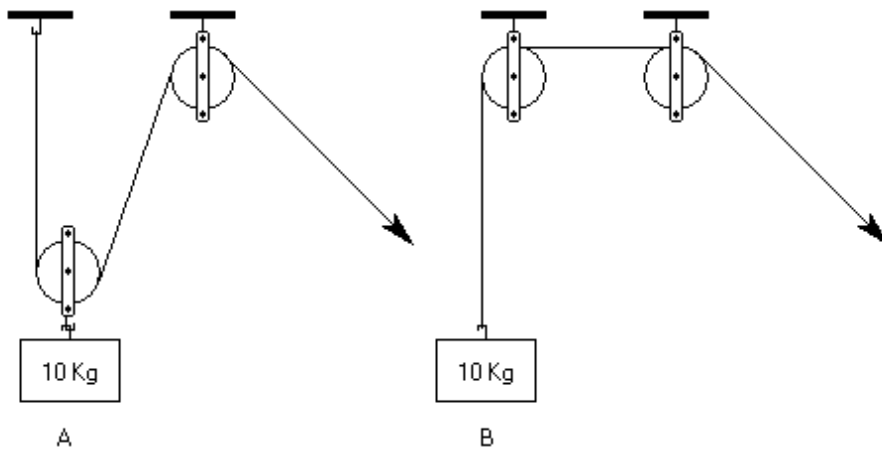

- A) A B) B C) Both require the same force

Answer

4. **A** – Weight A requires a force equal to 5 Kg whereas weight B requires a force equal to 10 Kg. Remember to divide the weight by the number of sections of rope supporting it to get the force needed to lift the weight.

Using More Than Two Pulleys

5. How much force is required to move the weight?

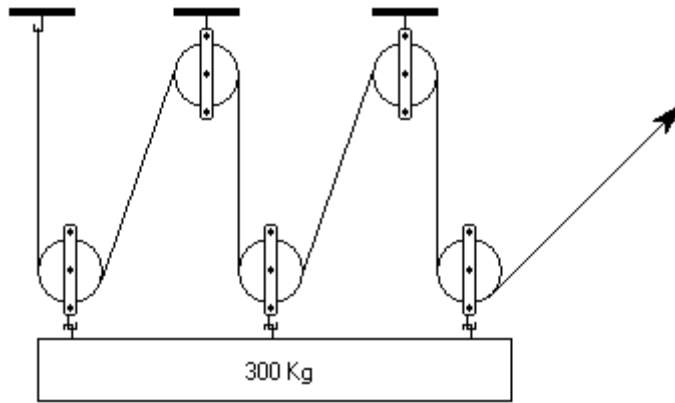

- A) 100 Kg B) 150 Kg C) 50 Kg D) 60 Kg

Answer

5. **C** – The weight is 300 kg and there are 6 sections of rope supporting it. Divide 300 by 6 to get 50 kg. In all cases just divide the weight by the number of sections of rope supporting it to get the force needed to lift the weight.

Gears

A gear is a toothed wheel or cylinder that meshes with another toothed component to transmit motion or to change speed or direction. Gears are attached to a rotating shaft turned by an external force, which is not usually illustrated in these types of question. Two gears may be connected by touching each other directly or by means of a chain or belt. If gears are connected by a chain or belt then they move in the same direction.



Gears Connected by Belt



Gears Meshed

If the gears are touching (meshed) then adjacent gears move in opposite directions. In this example the first and third gear will turn in the same direction. When there are an odd number of meshed gears then the last gear will always turn in the same direction as the first one.

Meshed gears with an equal number of teeth will turn at the same speed. If they have an unequal number of teeth then the gear with the fewest teeth will turn faster. To work out how fast one is turning with respect to the other you need to count the teeth.

Springs

A spring is piece of wire or metal that can be extended or compressed by an external force but which then returns to its original length when that force is no longer applied.

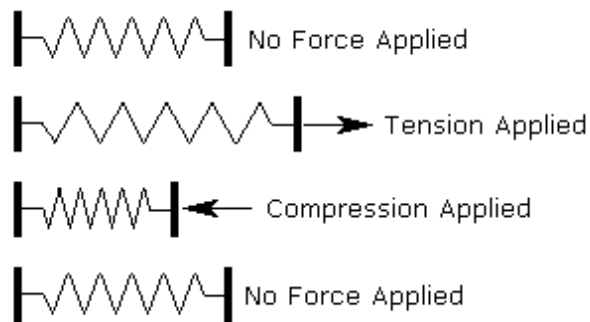

Spring Under Tension & Compression

There are many different types of spring including, spiral coil, leaf springs and torsion springs. Springs are used in many applications including clocks, vehicle suspensions etc. In the type of questions that you will be asked in mechanical aptitude tests, you can assume that springs behave in a linear way. That is, doubling the force applied will stretch or compress the spring twice as much.

Springs in Series & Parallel

If more than one spring is used then they can be arranged in one of two ways, either in series or in parallel.

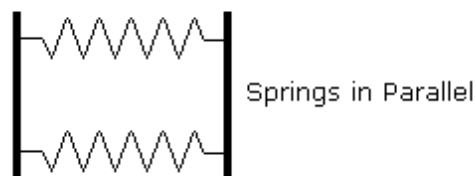

When springs are arranged in series, each spring is subjected to the force applied. When the springs are arranged in parallel the force is divided equally between the springs.

Example Question

6. A force of 5 Kg compresses the springs in series by 10cm. What will be the total distance that the springs in parallel are compressed?

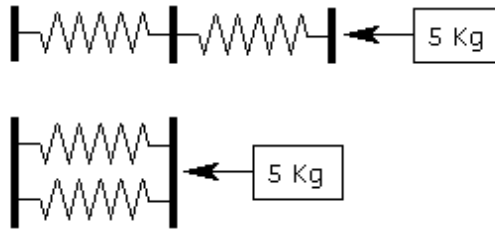

- A) 10 cms B) 2.5 cms C) 5 cms D) 7.5 cms

Answer

6. C – The total force will be divided equally between the 2 springs in parallel. Since the force is divided in half, the distance moved will also be halved. The springs in series were compressed by 10 cms, therefore the springs in parallel will be compressed by 5 cms.

Electricity

Questions on electricity usually take the form of simple circuit diagrams.

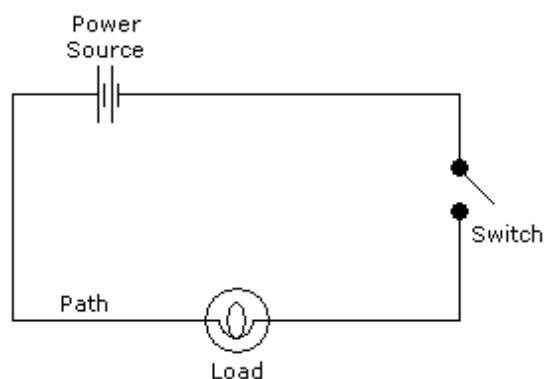

These diagrams are usually restricted to showing the power source, switches, loads (typically bulbs), and the path of the wiring. To answer these questions you need a basic understanding of how electricity flows around a circuit.

Example Question

7. How many switches need to be closed to light up one bulb?

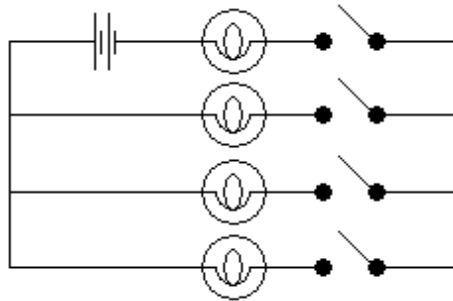

- A) 1 B) 2 C) 3 D) 4

8. How many bulbs will light up when the switch is closed?

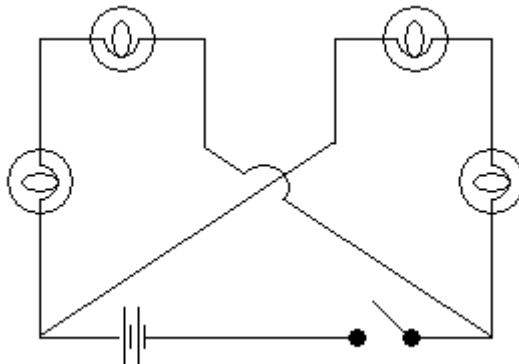

- A) 1 B) 2 C) 3 D) 4

9. If bulb 1 is removed, how many bulbs will light up when the switch is closed?

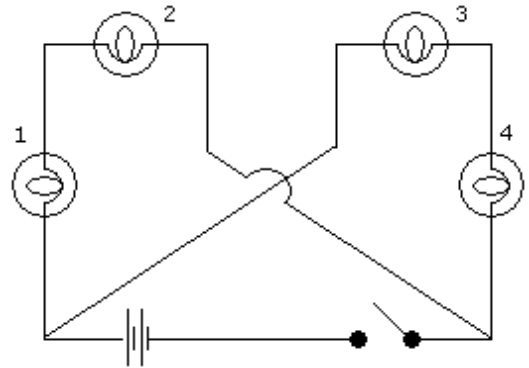

- A) 1 B) 2 C) 3 D) 0

Answers

- 7. B – Two switches need to be closed to complete a circuit.
- 8. D – All 4 bulbs will light up.
- 9. B – Only bulbs 3 and 4 will light up.

What is Magnetism?

Magnetism refers to physical phenomena arising from the force between magnets, objects that produce fields that attract or repel other objects.

All materials experience magnetism, some more strongly than others. Permanent magnets, made from materials such as iron, experience the strongest effects, known as ferromagnetism. This is the only form of magnetism strong enough to be felt by people.

Magnetic fields

A magnetic field is a way of mathematically describing how magnetic materials and electric currents interact. Magnetic fields have both a direction and a magnitude, or strength. Magnets have a "north" pole and a "south" pole. Opposite poles attract each other and alike poles repel each other. These poles are referred to as a magnetic dipole. Magnetic dipoles and electric currents both give rise to magnetic fields.

A magnet is what makes a compass point north — the small magnetic pin in a compass is suspended so that it can spin freely inside its casing and respond to our planet's magnetism. A compass needle aligns itself and points toward the top of Earth's magnetic field.

Magnetic force

Magnetic fields exert a force on particles in the field, called the Lorentz force. The motion of electrically charged particles gives rise to magnetism. The magnetic force acting on a single electric charge depends on the size of the charge, its speed, and the strengths of the electric and magnetic fields.

Electricity and magnetism

Both electric and magnetic interactions are elements of a single phenomenon called electromagnetism. There are four fundamental forces: the strong force, the weak force, gravitation and the electromagnetic force. The field of electromagnetism deals with how electrically charged particles interact with each other and with magnetic fields.

James Clerk Maxwell developed a unified theory of electromagnetism in 1873. There are four main electromagnetic interactions:

- The force of attraction or repulsion between electric charges is inversely proportional to the square of the distance between them.
- Magnetic poles come in pairs that attract and repel each other much as electric charges do.
- An electric current in a wire produces a magnetic field whose direction depends on the direction of the current.
- A moving electric field produces a magnetic field, and vice versa.

Linear Forces

In physics, one major player in the linear-force game is work; in equation form, work equals force times distance, or $W = Fs$. Work has a rotational analog. To relate a linear force acting for a certain distance with the idea of rotational work, you relate force to torque (its angular equivalent) and distance to angle.

When force moves an object through a distance, work is done on the object. Similarly, when a torque rotates an object through an angle, work is done. In this example, you work out how much work is done when you rotate a wheel by pulling a string attached to the wheel's outside edge (see the figure).

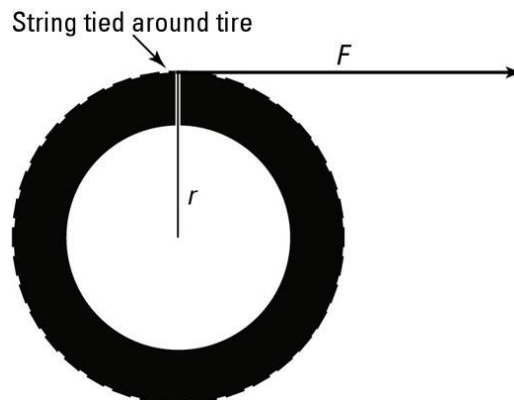

Work is the amount of force applied to an object multiplied by the distance it's applied. In this case, a force F is applied with the string. Bingo! The string lets you make the handy transition between linear and rotational work. So how much work is done? Use the following equation:

Reviewing The Basics

$$W = Fs$$

Where s is the distance the person pulling the string applies the force over. In this case, the distance (s) equals the radius (r) multiplied by the angle (θ) through which the wheel turns,

$$s = r\theta$$

so you get

$$W = Fr\theta$$

However, the torque, t , equals Fr in this case, because the string is acting at right angles to the radius. So you're left with

$$W = t\theta$$

When the string is pulled, applying a constant torque that turns the wheel, the work done equals

$$r\theta$$

This makes sense, because linear work is Fs , and to convert to rotational work, you convert from force to torque and from distance to angle. The units here are the standard units for work — joules in the MKS (meter-kilogram-second) system.

You have to give the angle in radians for the conversion between linear work and rotational work to come out right.

Other Things You May Need to Know

Some of the questions you come across may require knowledge of basic mathematics, fractions, decimals, ratios, percentages, and averages. These basic mathematical skills are an important aspect of mechanical ability and making simple calculations on the basis of the information provided and your knowledge of mechanical principles is part of these tests.

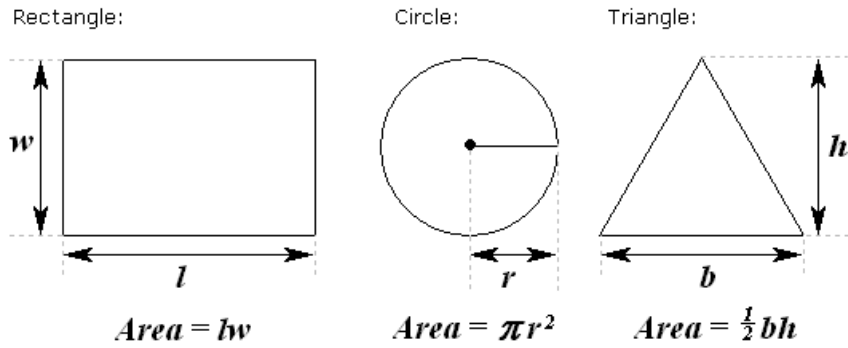

and some simple geometry like Pythagoras Theorem.

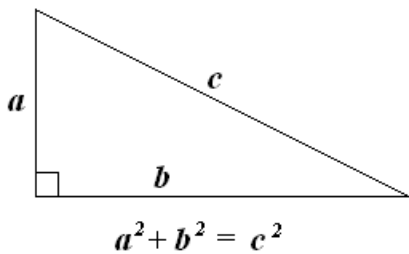

Reviewing The Basics

Now that you have finished a review of the basics, follow the directions on the test in following sections.

For each of the tests in the Self-Evaluation Test Series, instructions have been given which are very similar to the instructions that appear on the actual tests. Thus, to the extent possible, the actual conditions you would encounter in a testing situation been simulated in this Self-Evaluation guide.

In working through each individual test, you are encouraged to read the test directions over carefully, and then work through the actual self-evaluation questions either timing yourself, or having someone else time you. Your timing should be exact since a few seconds one way or the other can make a difference. Moreover, the timing for the actual Selection Test Series will be precise.

When you have completed a section, go to the appropriate Answer Key and check your answers. Compare your score to the standard scores given at the bottom of each Answer Key.

If your score is notably above the standard scores given on the answer key, you can have some confidence that you should be able to perform acceptably on the Section Test Series. If you are very close to the standard score or below it, you may well want to do some additional studying and skills development in order to have more confidence that you will be able to work successfully through the Apprenticeship Selection Test Series.

To assist you in this regard, a number of self-development suggestions have been included at the end of several self-evaluation sections.

We hope you find this Self-Evaluation to be of assistance and wish you the best in the pursuit of a possible career in the Trades.

SECTION 2: GENERAL PROBLEM SOLVING ABILITY

Directions

This is a sample test of your problem solving ability. It contains various types of questions. Give yourself 5 minutes to work on as many as you can. You probably will not be able to finish them all, but do your best. Do not go so fast that you make mistakes since you must try to get as many right as possible. The questions become increasingly difficult, so do not skip about. Do not spend too much time on any one problem.

Below are sample questions correctly filled in.

Throw is the opposite of

The correct answer is “catch.” (it is helpful to underline the correct word.) The correct word is numbered 3. Then write the number 3 in the brackets at the end of the line.

Chocolate bars sell for 74 cents each. What will 4 bars cost?

The correct answer is \$2.96.

There is nothing to underline so just write \$2.96 in the brackets.

HIM HYMN Do these words:

1. Similar meanings
2. Contradictory
3. Mean neither the same nor different

The correct answer is “mean neither the same nor different” which is number 3, so all you have to do is write the number 3 in the brackets at the end of the line.

When the answer to a question is a letter or a number, put the letter or the number in the brackets. All letters should be printed.

Now give yourself 5 minutes. Turn the page and begin.

Test 1: General Problem Solving Ability

General Problem Solving Ability

1. CONTENTED is the opposite of
1. Happy 2. Sad 3. Dissatisfied 4. Sweet 5. Pleased (____)
2. Look at row of numbers below. What number should come next?
83 75 67 59 51 43 ? (____)
3. FLAMMABLE INFLAMMABLE – Do these words have
1. Similar meaning 2. Contradictory 3. Mean neither the same nor different (____)
4. FICKLE is the opposite of
1. Flighty 2. False 3. Faithful 4. Feckless 5. Stubborn (____)
5. In the following set of words, which one is different from the others?
1. Italian 2. French 3. English 4. Foreign 5. Spanish (____)
6. Are the meaning of the following sentences:
A penny saved is a penny earned. Neither a borrower nor a lender be
1. Similar 2. Contradictory 3. Mean neither the same nor different (____)
7. Flour costs $8\frac{1}{2}$ cents per pound. How much do you save by bulk buying a 100 pound sack for \$8.25?
(____)
8. Suppose you arranged the following words so that they made a true statement. Then print the last letter of the last word as the answer to this problem.
cherries All fruit are (____)
9. Assume the first 2 statements are true. Is the final one:
1. True 2. False 3. Not certain (____)
These children are playing soccer
Boys play soccer
These children are boys

Test 1: General Problem Solving Ability

10. A boy is 10 years old and his sister is half as old. When the boy is 15 years old, what will be the age of his sister?

()

11. How many of the five items listed below are exact duplicates of each other?

Smithrite, J.C
Percival, W.S.
Pollauf, A.S.
Grenfeld, F.E.
Walker, S.R.

Smithrite, J.G.
Percivale, W.S.
Pollauf, A.S.
Grenfield, F.E.
Walker, S.R.

()

12. A watch loses 3 minutes every day. How many days will it take for the watch to be exactly one hour behind?

()

13. This geometric figure can be divided by a straight line into two parts which will fit together in a certain way to make a perfect square. Draw such a line by joining two of the numbers. Then write these numbers as the answer.

()

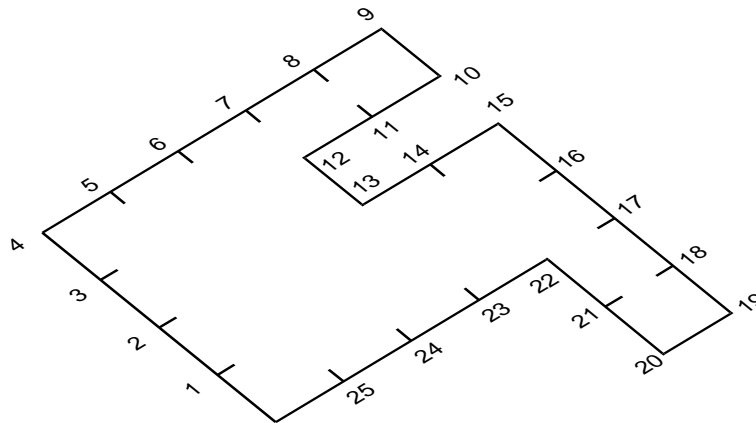

Test 1: General Problem Solving Ability

14. A car travels 90 kilometers per hour. At this speed, how many kilometers will it travel in 3.5 minutes?

()

15. Are the meanings of the following sentences:

Nothing ventured nothing is gained. Better safe than sorry

1. similar

2. contradictory

3. Neither similar nor
contradictory

()

16. When ribbon is selling at \$0.05 a foot, how many feet can you buy for a dollar?

()

17. Which number in the following group of numbers represents the smallest amount?

$\frac{1}{2}$ $\frac{3}{16}$ $\frac{1}{4}$ $\frac{3}{8}$ $\frac{3}{32}$ 1

()

18. Two of the following proverbs have opposite meanings. Which one are they?

1. look before you leap

2. a stitch in time save nine

3. he who hesitates is lost

4. a penny saved is a penny earned

5. Pride goeth before the fall

()

19. Assume the first 2 statements are true. Is the final one:

1. true

2. false

3. not certain

()

I am in a hurry

Busy people are in a hurry

I am busy

20. For \$4.50 a grocer buys a case of eggs which contains 12 dozen. He knows that two dozen are broken and must be thrown away. At what price per dozen must he sell the good ones to gain $\frac{1}{3}$ of the whole cost?

()

End of Section: Go to Answer Key on Page 66

SECTION 3: MECHANICAL REASONING

Directions

This is a test of your mechanical reasoning. It contains various types of questions. Give yourself 6 minutes to work on as many as you can. You probably will not be able to finish them all, but do your best. Do not go so fast that you make mistakes since you must try to get as many right as possible. Do not spend too much time on any one problem.

Now look at Sample X on this page. It shows a picture of three cans, previously sealed which have been salvaged from a hot fire. "Which picture would the can most likely resemble? Because the can had been sealed, the heat building up inside would cause the contents to be forced out through the top. Therefore, the A is the correct answer and the letter A has been circled. Now look at sample Y and answer it yourself. Indicate the correct answer by circling letter A, B or C.

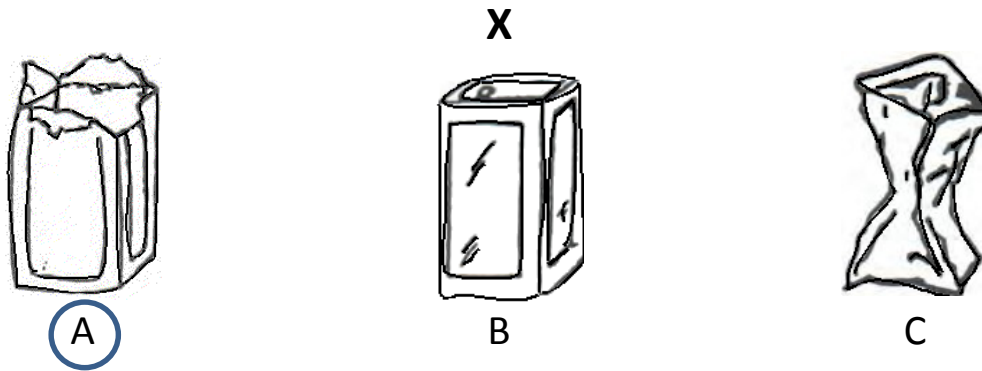

Which clamp will hold work together tighter with the same pressure on the turnkey

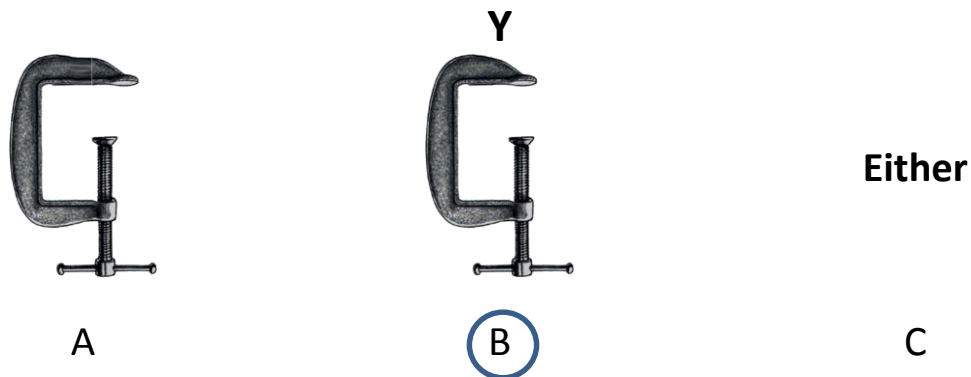

The correct answer is B, so you should have circled B as seen above.

Now do the following questions, indicating your answer by circling the appropriate letter. Give yourself 6 minutes to complete the questions.

Section 2: Mechanical Reasoning

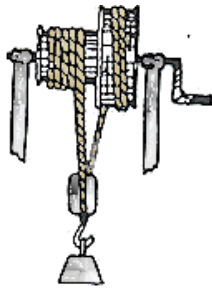

1. If the windlass were turned in the direction indicated by the arrow, would the weight:

- A. Move up
- B. Move down
- C. Stay in the same position

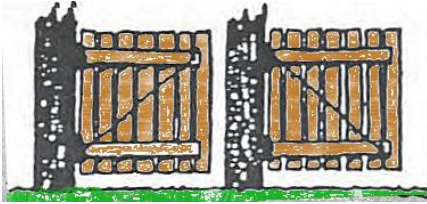

A

B

2. Which gate would be stronger?

- A. Gate A
- B. Gate B
- C. Same

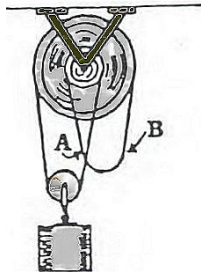

3. Where would you pull to raise the weight?

- A.
- B.
- C. Either



4. Which screw would be harder to screw into hard wood?

- A.
- B.
- C. Either

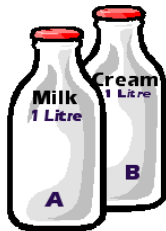

5. Which is heavier?

- A.
- B.
- C. Equal

Section 2: Mechanical Reasoning

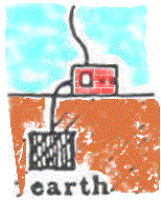

A.



B.

6. Which would be the better ground connection for a radio?

- A. Earth
- B. Water
- C. Either

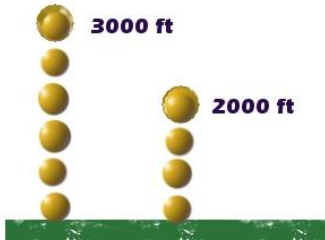

7. Objects "A" and "B" fall to the ground from the heights indicated. Which will be falling faster when it reaches the ground?

- A. first diagram
- B. second diagram
- C. Neither

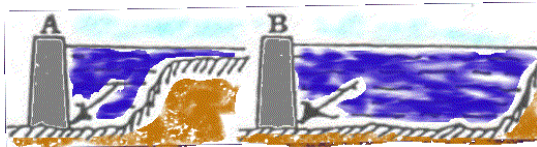

8. In which diagram would the water pressure be greater at the points indicated by the arrow?

- A.
- B.
- C. Neither



9. Which of the two shelves will support the heavier weight?

- A.
- B.
- C. Equal

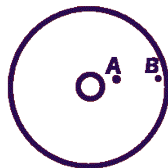

10. Which spot on the wheel would travel faster?

- A.
- B.
- C. Neither

End of Section 2: Go to Answer Key Page 67

SECTION 4: DETAIL CHECKING ABILITY

Directions

This is a test of your detail checking ability. Give yourself 3 minutes to work on as many questions as you can. You probably will not be able to finish them all, but do your best. Do not go so fast that you make mistakes since you must try to get as many right as possible. Do not spend too much time on any one problem.

The sample table below shows the manufacturers of four different types (A, B, C, and D) of tools (bevel , clamp, drill press, etc.)

Tool	Type A	Type B	Type C	Type D
Bevel	ALTO	FGR	HASCO	MPT
Clamp	BROWN	ALTO	MPT	HASCO
Drill Press	MPT	BROWN	ALTO	HASCO
Square	BROWN	MPT	HASCCO	FGR
Vise	ALTO	HASCO	MPT	BROWN

Look at the sample problems below. In the first problem you are asked for the name of the company that manufactures a Type B Clamp. Find Clamp in the column labeled Tool in the Sample Table. Read across this line to the column headed Type B, And you will find the name ALTO. In the sample answer space the first letter of the manufacturing company has been circled (A for ALTO). Now, find the name of the company that manufactures a Type C Vise, and check your answer against the answer that is indicated in the sample answer space at the right.

ALTO	BROWN	FGR	HASCO	MPT
A	B	F	H	M

Tool and Type

S1. Clamp – Type B	S1.	A	B	F	H	M
S2. Vice – Type C	S1.	A	B	F	H	M

Give yourself three (3) minutes to complete this test. The Table and the questions are on the following page.

Section 3: Detail Checking

Detail Checking Ability

Table 1

TOOL	Type A	Type B	Type C	Type D	TOOL	Type A	Type B	Type C	Type D
Awl	ALTO	FGR	HASCO	HASCO	Plane, Grooving	MPT	BROWN	FGR	ALTO
Brace	BROWN	ALTO	MPT	HASCO	Plane, Jack	FGR	MPT	ALTO	HASCO
Calipers, Inside	MPT	BROWN	ALTO	HASCO	Ratchet, Drill	BROWN	FGR	HASCO	MPT
Calipers, Outside	BROWN	MPT	HASCO	FGR	Saw, Hack	MPT	HASCO	BROWN	FGR
Divider	ALTO	HASCO	MPT	BROWN	Saw, Rip	HASCO	MPT	ALTO	BROWN
File	MPT	ALTO	FGR	HASCO	Soldering Iron P.	BROWN	FGR	HASCO	ALTO
Hammer, Claw	HASCO	MPT	BROWN	FGR	Soldering Iron E.	HASCO	ALTO	FGR	MPT
Hammer, Machinist's	BROWN	FGR	HASCO	ALTO	Whetstone	ALTO	HASCO	BROWN	FGR
Level	BROWN	HASCO	MPT	FGR	Wrench, Pipe	MPT	BROWN	FGR	ALTO
Marking Gauge	FGR	ALTO	BROWN	HASCO	Wrench, Monkey	BROWN	FGR	ALTO	MPT

Circle A for ALTO, B for BROWN, F for FGR, H for HASCO, and M for MPT

TOOL AND TYPE

1. Brace – Type B	A	B	F	H	M	16. Saw, Hack – Type C	A	B	F	H	M
2. Divider – Type C	A	B	F	H	M	17. Hammer, Machinists - Type A	A	B	F	H	M
3. Whetstone – Type D	A	B	F	H	M	18. Soldering Iron P. – Type B	A	B	F	H	M
4. File – Type A	A	B	F	H	M	19. Level – Type C	A	B	F	H	M
5. Wrench, Pipe – Type B	A	B	F	H	M	20. Saw, Rip – Type A	A	B	F	H	M
6. Level – Type D	A	B	F	H	M	21. Whetstone – Type B	A	B	F	H	M
7. Saw, Rip – Type B	A	B	F	H	M	22. File – Type B	A	B	F	H	M
8. Marking Gauge – Type B	A	B	F	H	M	23. Wrench, Pipe – Type C	A	B	F	H	M
9. Wrench, Monkey – Type A	A	B	F	H	M	24. Divider – Type D	A	B	F	H	M
10. Calipers, Outside – Type C	A	B	F	H	M	25. Soldering Iron E. – type A	A	B	F	H	M
11. Awl – Type A	A	B	F	H	M	26. Calipers, Outside – Type D	A	B	F	H	M
12. Plane, Jack – Type C	A	B	F	H	M	27. Hammer, Claw – Type A	A	B	F	H	M
13. Ratchet, Drill – Type C	A	B	F	H	M	28. Plane, Jack – Type A	A	B	F	H	M
14. Plane, Grooving – Type C	A	B	F	H	M	29. Awl – Type D	A	B	F	H	M
15. Calipers, Inside – Type C	A	B	F	H	M	30. Ratchet Drill – Type A	A	B	F	H	M

End Section 3: Go to Answer Key Page 69

SECTION 5: ARITHMETIC ABILITY

Directions

This is a sample test of your ability to do numerical computations quickly and accurately. It contains various types of questions. Give yourself 3 minutes to work on as many as you can. You probably will not be able to finish them all but do your best. Do not go so fast that you make mistakes since you must try to get as many right as possible. Do not spend too much time on any one problem.

Sample problems of the type you will find in the test are given below. The answers have been marked beside the questions. Study the problems, calculate the answers and check your numbers with the answers that are given in the sample answer spaces at the right.

S1.	6	+3	+9	+7	=	A	B	C	D	E	A	B	C	D	E
						33	15	27	25	29	<input type="radio"/>	<input type="radio"/>	<input type="radio"/>	<input checked="" type="radio"/>	<input type="radio"/>
S2.	49	+5	-3	+7	=	66	58	78	74	69	<input type="radio"/>	<input checked="" type="radio"/>	<input type="radio"/>	<input type="radio"/>	<input type="radio"/>

Give yourself 3 minutes for this test. You are not expected to be able to do all of the problems in the time limits given, but work as quickly and as accurately as you can.

Section 4: Arithmetic Ability

Arithmetic Ability

Add

						A	B	C	D	E	A	B	C	D	E
1.	8	+2	+5	+5	=	16	20	36	22	28	0	0	0	0	0
2.	4	+1	+9	+9	=	23	24	20	33	19	0	0	0	0	0
3.	9	+2	+5	+9	=	16	18	35	25	30	0	0	0	0	0
4.	3	+2	+8	+2	=	14	11	13	17	15	0	0	0	0	0
5.	1	+3	+9	+8	=	18	24	28	21	23	0	0	0	0	0
6.	2	+5	+8	+6	=	27	25	26	21	28	0	0	0	0	0
7.	2	+8	+4	+8	=	21	24	23	22	27	0	0	0	0	0
8.	9	+7	+7	+7	=	22	27	28	30	24	0	0	0	0	0
9.	6	+7	+5	+6	=	23	17	24	25	21	0	0	0	0	0
10.	4	+8	+8	+5	=	25	30	32	29	31	0	0	0	0	0
11.	5	+9	+4	+8	=	21	28	30	26	22	0	0	0	0	0
12.	7	+3	+6	+1	=	13	15	12	17	16	0	0	0	0	0
											0	0	0	0	0

Subtract

						A	B	C	D	E	A	B	C	D	E
13.	34	-8	-2	-3	=	31	30	27	21	26	0	0	0	0	0
14.	69	-9	-7	-3	=	53	50	56	55	54	0	0	0	0	0
15.	97	-7	-6	-1	=	83	78	81	95	90	0	0	0	0	0
16.	80	-6	-5	-8	=	71	63	58	61	65	0	0	0	0	0
17.	31	-8	-6	-9	=	10	8	9	6	7	0	0	0	0	0
18.	43	-4	-5	-2	=	26	28	32	29	34	0	0	0	0	0

Turn page and continue...

Section 4: Arithmetic Ability

Arithmetic Ability

Add and Subtract as indicated

						A	B	C	D	E	A	B	C	D	E
19.	63	+3	-7	+2	=	67	61	63	57	65	<input type="radio"/>	<input type="radio"/>	<input type="radio"/>	<input type="radio"/>	<input type="radio"/>
20.	82	-9	+1	+4	=	78	77	79	85	75	<input type="radio"/>	<input type="radio"/>	<input type="radio"/>	<input type="radio"/>	<input type="radio"/>
21.	91	-4	+7	-7	=	90	56	87	70	78	<input type="radio"/>	<input type="radio"/>	<input type="radio"/>	<input type="radio"/>	<input type="radio"/>
22.	39	-3	-5	-8	=	15	25	27	23	17	<input type="radio"/>	<input type="radio"/>	<input type="radio"/>	<input type="radio"/>	<input type="radio"/>
23.	47	+9	+9	+6	=	71	68	61	63	67	<input type="radio"/>	<input type="radio"/>	<input type="radio"/>	<input type="radio"/>	<input type="radio"/>
24.	38	+7	+6	-1	=	49	53	50	60	58	<input type="radio"/>	<input type="radio"/>	<input type="radio"/>	<input type="radio"/>	<input type="radio"/>

Multiply

						A	B	C	D	E	A	B	C	D	E
25.		26	×	4	=	72	78	104	147	198	<input type="radio"/>	<input type="radio"/>	<input type="radio"/>	<input type="radio"/>	<input type="radio"/>
26.		32	×	5	=	199	172	160	165	196	<input type="radio"/>	<input type="radio"/>	<input type="radio"/>	<input type="radio"/>	<input type="radio"/>
27.		57	×	4	=	227	246	236	228	233	<input type="radio"/>	<input type="radio"/>	<input type="radio"/>	<input type="radio"/>	<input type="radio"/>
28.		72	×	6	=	154	497	477	539	432	<input type="radio"/>	<input type="radio"/>	<input type="radio"/>	<input type="radio"/>	<input type="radio"/>
29.		51	×	9	=	459	524	448	504	494	<input type="radio"/>	<input type="radio"/>	<input type="radio"/>	<input type="radio"/>	<input type="radio"/>
30.		34	×	8	=	264	266	231	272	284	<input type="radio"/>	<input type="radio"/>	<input type="radio"/>	<input type="radio"/>	<input type="radio"/>

Divide

						A	B	C	D	E	A	B	C	D	E
31.		117	÷	7	=	17	13	15	14	16	<input type="radio"/>	<input type="radio"/>	<input type="radio"/>	<input type="radio"/>	<input type="radio"/>
32.		108	÷	9	=	17	21	18	13	12	<input type="radio"/>	<input type="radio"/>	<input type="radio"/>	<input type="radio"/>	<input type="radio"/>
33.		186	÷	6	=	28	33	31	34	24	<input type="radio"/>	<input type="radio"/>	<input type="radio"/>	<input type="radio"/>	<input type="radio"/>
34.		180	÷	5	=	36	32	38	34	40	<input type="radio"/>	<input type="radio"/>	<input type="radio"/>	<input type="radio"/>	<input type="radio"/>
35.		72	÷	6	=	21	18	12	19	13	<input type="radio"/>	<input type="radio"/>	<input type="radio"/>	<input type="radio"/>	<input type="radio"/>
36.		126	÷	7	=	17	31	15	12	18	<input type="radio"/>	<input type="radio"/>	<input type="radio"/>	<input type="radio"/>	<input type="radio"/>

End Section 4: Go to Answer Key

SECTION 6: JUDGMENT AND COMPREHENSION

Directions

This is a test of your ability to understand what you read. You will be asked to answer questions based on the material contained in written passages.

Begin by reading the passage carefully. Then answer the questions by marking an “X” in the circle before the alternative which best completes the statement or answers the question. Answer the questions about one passage before going on to the next. You may look back at the passage while you answer the questions. Work carefully but rapidly.

Allow yourself 12 minutes to work on this section of the test. There are three passages and sets of questions. Each passage appears on a separate page.

Section 6: Judgment and Comprehension

Judgment and Comprehension: Passage One

In the modern world, two sets of rules govern the flight of all aircraft. One is called VFR, for visual flight rules, and it governs flight under conditions of acceptable visibility - when the pilots can see where they are going and what other traffic may be in the vicinity. VFR conditions are prescribed and marked on aeronautical charts; they may vary from country to country or even locality to locality.

IFR, for instrument flight rule, controls all flights under conditions of restricted visibility - in clouds, rain, snow, fog and so on. Under IFR, actual control of the airplane passes from the pilot to a controller in a ground station equipped with a variety of complex instruments (chiefly radar). The air traffic controller observes the airplane's movements and by voice radio tells the pilot which speed, altitude, and course to fly while also warning the pilot of other traffic in the vicinity.

To the pilot flying IFR, the sky may be a mass of grayish cotton-wool: to the ground controller, it is a radar screen filled with numerous yellow blips, each representing an airplane. Each airplane has attached to it a data block identifying it by number and giving its speed, altitude, and course. When two blips are on a converging course, the controller instructs one of them to change altitude or course or both to avoid collision. If the airplane is in a terminal area and intends to land, the controller governs its flight all the way to touchdown on the runway, and sometimes beyond.

VFR, visual flight rules, govern flight under conditions of:

- Unacceptable visibility
- Acceptable visibility
- Restricted visibility
- Total visibility
- Poor weather

Under IFR, control of the aircraft is dictated by:

- The pilot
- The air traffic controller
- Both the pilot and controller
- RADAR
- All of the above

VFR conditions vary from country to country and even locality to locality. Pilots learn about them from:

- The air traffic controller
- Runway signs
- Voice radio
- Aeronautical charts
- Other pilots

Under VFR conditions, control of the airplane belongs to:

- Air traffic controller
- Controller
- Ground controller
- All the above
- None of the above

The air traffic controller can identify each airplane on his/her screen by:

- The colour of its radar blip
- The name of its airline
- The number, speed, altitude, and course
- VFR or IFR
- None of the above

Which of the following words might be used to describe the content of this passage:

- Factual
- Analytical
- Fanciful
- Opinionated
- Statistical

Turn the page and continue

Section 6: Judgment and Comprehension

Judgment and Comprehension: Passage Two

In spite of the fact that Canada has always been a great trading nation, it is not a nation of traders because an enormous percentage of our trade has been in commodities—and commodities are bought, not sold. Consequently, our business people have not been forced to hustle around the globe to sell their products. This must change.

Over the past two decades, commentators analyzing the future of our economy have stressed ad nauseam that the technological revolution in transportation and communications—and the institutional changes that are responsible for the dismantlement of trade barriers among nations—have led to the creation of one world market for the production and sale of goods and services.

The implications of these changes for business are simple yet immense—simple in the sense that businesses everywhere are subject to competition, and immense because adjusting to competitive forces requires sweeping reforms in management practices. As everyone is reminded, businesses that are incapable of responding to these forces will fail; fortunately, in Canada there are literally hundreds of small, medium and large business organizations that are seeking out and capturing new markets for Canadian products.

A fact about Canadian business people is that they:

- Are traders
- Have not marketed their products internationally
- Prefer buying to selling
- Like to travel
- Are successful

Economic Analysts have stressed that because of technological revolutions and institutional changes:

- Trade barriers exist between nations
- Trade has increased in transportation and communications
- One world market for goods and services has been created
- Competition has decreased
- Businesses have failed

For businesses to succeed, they must

- Make sweeping reforms in management practices
- Adjust to competitive forces
- Seek and capture new markets
- Have a global perspective
- All of the above

The author's style might be characterized as:

- Humorous
- Expository
- Whimsical
- Controversial
- Satirical

The best title for this passage would be:

- How to Succeed in Business
- The Marketplace
- Global Trade Competition
- Canada, A Trading Nation
- Commodities

Turn page and continue...

Section 6: Judgment and Comprehension

Judgment and Comprehension: Passage Three

An attitude exists that democracy is a nice way of life for nice people, despite its manifold inconveniences – a kind of expensive and inefficient luxury, like owning a large medieval castle. Feelings about are for the most part affectionate, even respectful, yet a little impatient. There are probably few people in North America who have not at some time nourished in their hearts the blasphemous thought that life would go much more smoothly if democracy could be relegated to some kind of Sunday morning devotion.

The bluff practicality of the "nice but inefficient" stereotype masks a hidden idealism, however, for it implies that institutions can survive in a competitive environment through the sheer good-heartedness of those who maintain them. We challenge this notion. Even if all those benign sentiments were eradicated today, we would awaken tomorrow to find democracy still entrenched, buttressed by a set of economic, social and political forces as practical as they are uncontrollable.

Democracy has been so widely embraced not because of some vague yearning for human rights but because under certain conditions it is a more "efficient" form of social organization. (Our concept of efficiency includes the ability to survive and prosper.) It is not accidental that those nations of the world that have endured longest under conditions of relative wealth and stability are democratic, while authoritarian regimes have, with few exceptions, either crumbled or eked out a precarious and backward existence.

Democracy... is the only system that can successfully cope with the changing demands of contemporary civilization. We are not necessarily endorsing democracy as such; one might reasonably argue that industrial civilization is pernicious and should be abolished. We suggest merely that given a desire to survive in this civilization, democracy is the most effective means to this end.

According to the author of this passage, democracy is the most viable form of government because:

- It's a nice way of life for nice people
- It respects human rights
- It has endured for a long time
- It copes most efficiently with the changing demands of contemporary civilization
- It has been widely embraced

In the last paragraph, according to the context of the sentence, the word pernicious likely means:

- Exceedingly harmful
- Inflexible
- Ineffective
- Inefficient
- Impractical

What condition(s) of a democratic nation does the author cite as proof of its effectiveness?

- Religious devotion
- Niceness
- Hidden idealism
- Good heartedness
- Duration of wealth and stability

The attitude of the author of this passage toward democracy seems to be basically one of:

- Affectionate respect
- Strong endorsement
- Ironic detachment
- Practical recommendation
- Blasphemous rejection

Section 6: Judgment and Comprehension

A good title for this passage might be:

- The Nature of Democracy
- Democracy and Contemporary Industrial Civilizations
- Why Democracy?
- Democracy vs. Authoritarianism

End of Section 5: Go to Answer Key Page 71

SECTION 7: SPATIAL REASONING (MECHANICAL TRADES ONLY)

In this exercise, you are given two sets of pictorial drawings (one on this page, one on the next.) The first set is labeled A through M, the second labeled N through Y. On the right of each of these sets of drawings are two additional sets of drawings numbered 1 through 12 and 13 through 24. Each numbered box shows a figure from three perspectives (Orthographic Views):

- The top view shows the figure, as it would look from above, looking down on it.
- The bottom view shows the figure from the front.
- The view on the right shows the figure as viewed from the right side.

Your task is to match each pictorial drawing in the lettered series with its counterpart on the right in the numbered drawings. For example, Pictorial Picture A matches drawing 7. Then do the same for the second set on the following page.

Allow yourself 5 minutes to do all the questions in both sets. Mark your answers following each set of pictures.

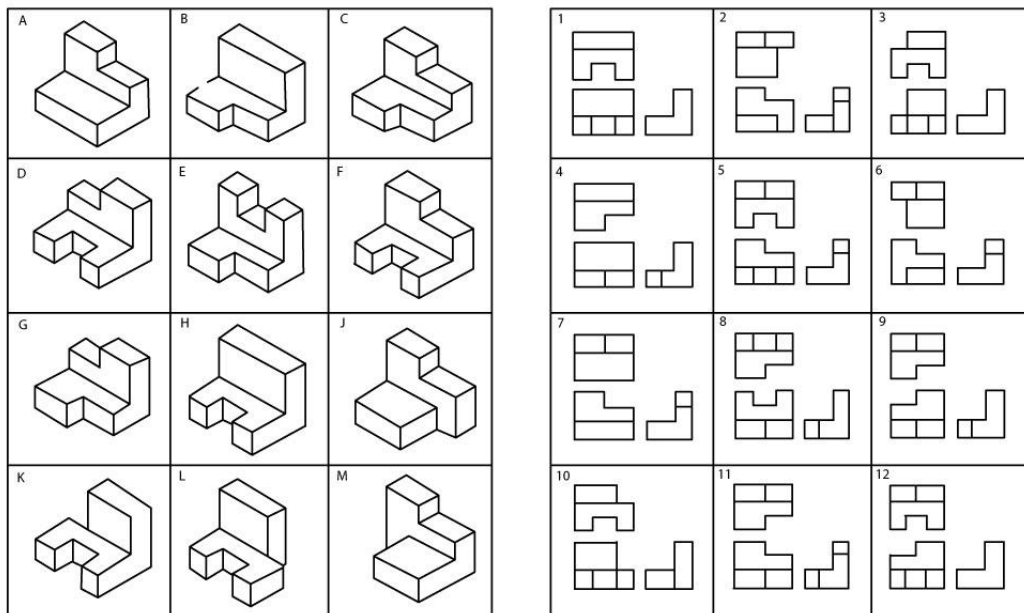

A	(7)		H	()
B	()		I	(_xx_)
C	()		J	()
D	()		K	()
E	()		L	()
F	()		M	()
G	()			

Note: diagram "I" does not exist

Turn the page and continue...

Section 7: Spatial Reasoning (Mechanical Trades Only)

Set Two

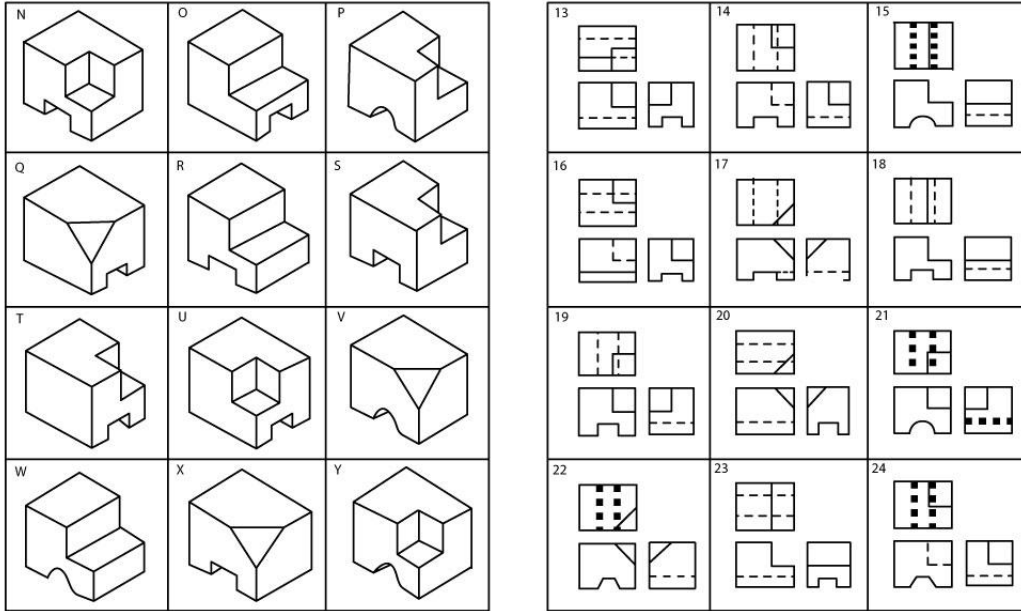

N	()	
O	()	
P	()	
Q	()	
R	()	
S	()	
T	()	
U	()	
V	()	
W	()	
X	()	
Y	()	

End of Section 6: Go to Answer Key Page 73

SECTION 8: SPATIAL REASONING – FINE MOTOR COORDINATION AND WORKING WITH PATTERNS (ELECTRICAL TRADES ONLY)

Directions

This is a test of your ability to copy patterns accurately. You are to look at the pattern shown by the heavy line in the drawing, and copy the pattern by drawing a line yourself, starting at the point marked



For example, if the drawing looks like this:

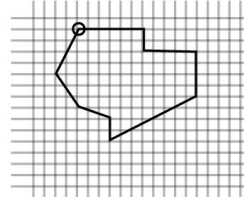

You should draw a line like this:

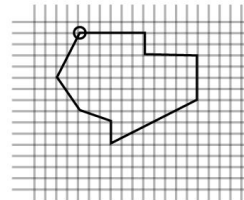

Your line must make a pattern that is exactly the same as the
Do the sample problem below:

pattern shown.

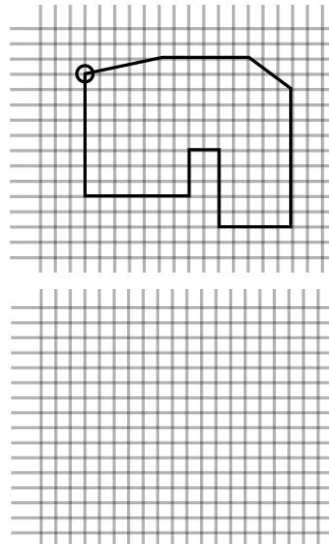

To begin, start in the upper left hand corner of the paper and copy the patterns, placing your drawing in the blank spaces. Do not lift your pencil off the paper except at the end of a pattern. Do not retrace or erase any line. Give yourself 3 minutes for this test.

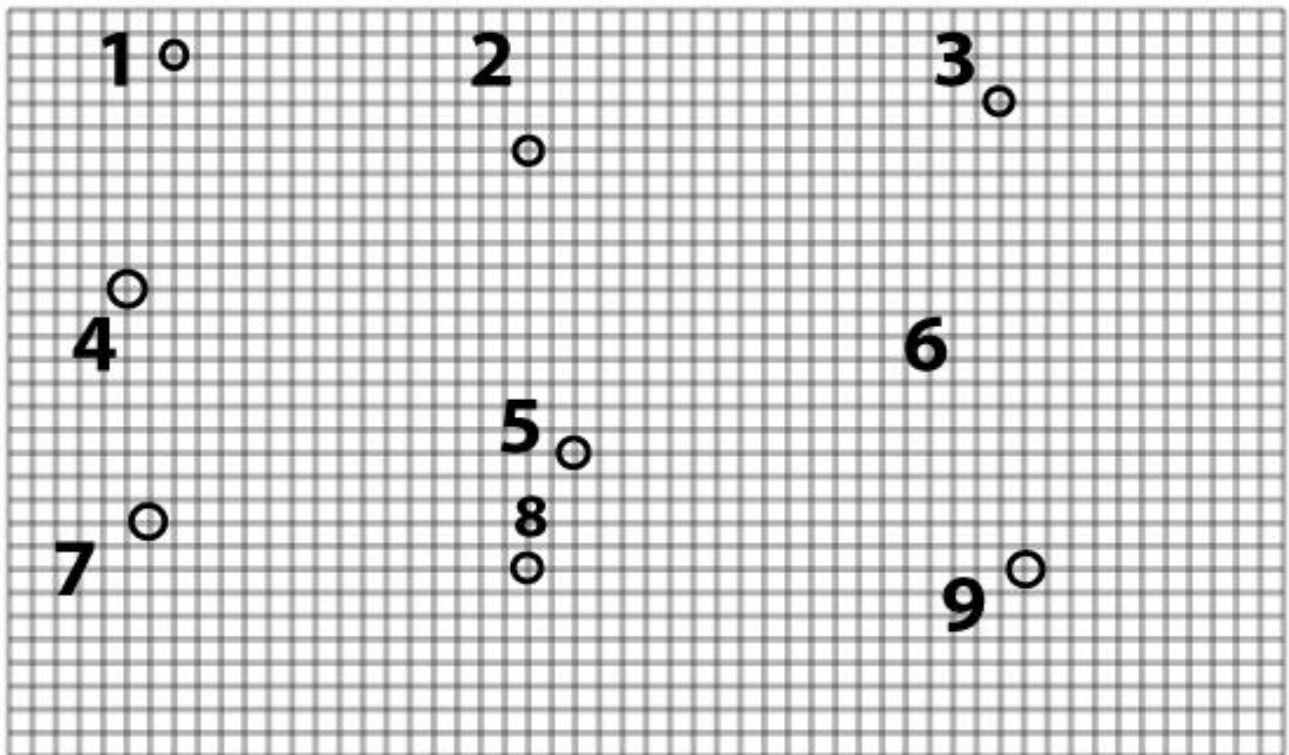
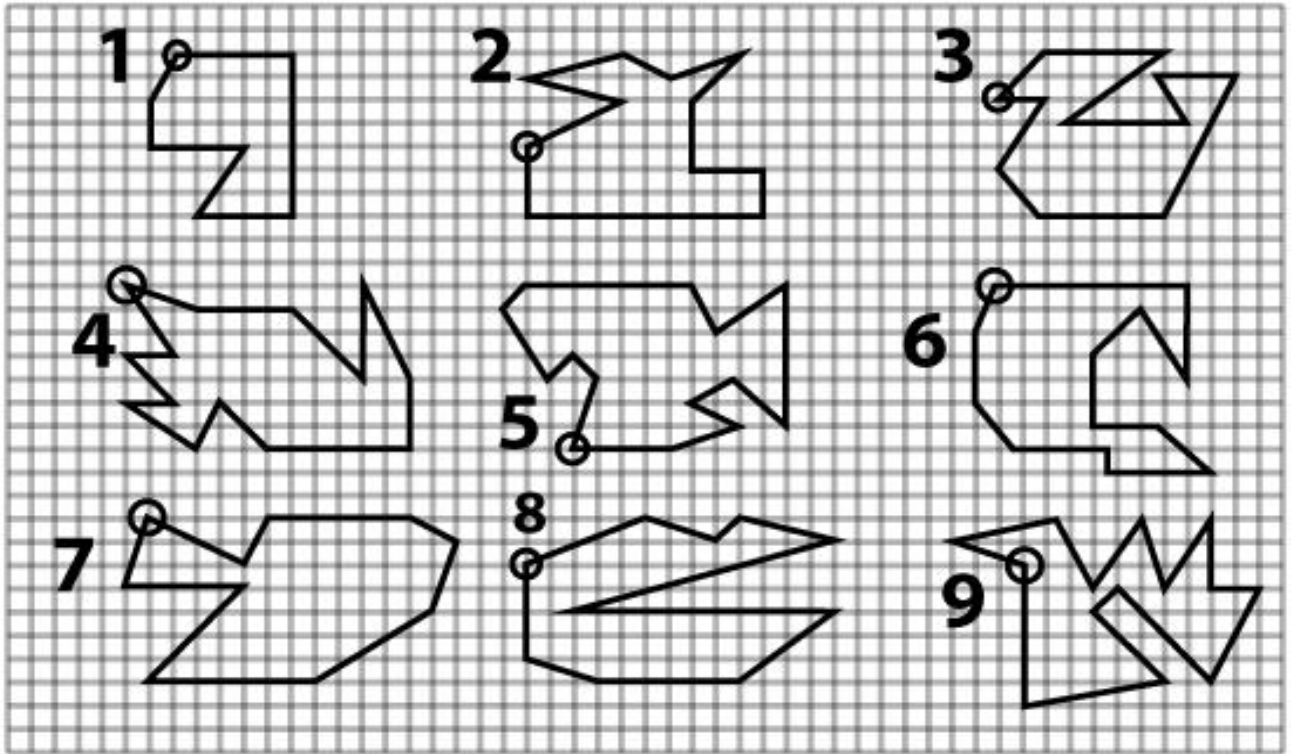

SECTION 9: REASONING AND MATHEMATICAL SYMBOLS (ELECTRICAL TRADES ONLY)

Directions

This is a sample test of your ability to reason and to express problems in simple form using conventional mathematic symbols. Do not go so fast that you make mistakes since you must try to get as many right as possible. Do not spend too much time on any one problem. Give yourself 8 minutes to complete this section.

Your task is to read each problem and to formulate an answer for it. Then look at the five alternative choices and mark an "X" in the box before the choice which correctly completes the problem.

Practice Problem

Read the sample problem below and think of the answer which will complete the problem correctly.

There were G person in a group who all ordered the special lunch at a restaurant. The amount of the bill was D dollars. The amount owed by each person was:

- GD $\frac{D}{G}$ $\frac{G}{H}$ $D - G$ $\frac{G + D}{I}$

The correct solution to the sample problem is $\frac{D}{G}$. Therefore an "X" has been marked in the box before this answer.

Give yourself 8 minutes to do the following test. Turn the page and begin.

Reasoning and Mathematical Symbols

1. A person bought a badminton net for which he paid D dollars, a set of 6 birdies for B dollars and two special rackets for which he paid P dollars each. The total cost of his purchases in dollars is:

$D + 6B + 2P$ $DB + 2P$ $D + \frac{B}{6} + 2P$

$D + B + 2P$ $D + \frac{B}{6} + \frac{P}{2}$

2. If E is less than F , F is less than G , G is equal to H , and H is less than I , which of the following represents the smallest value?

$\frac{E}{F}$ $\frac{G}{H}$ $\frac{E}{I}$

$\frac{F}{H}$ $\frac{H}{I}$

3. An appliance shop charges a service fee per repair of A dollars plus D dollars per hour for repairman's labour, and batteries cost R cents each. If it takes two hours for a repairman to complete a radio tune up and four new batteries are put in, the total bill in dollars will be:

$\frac{A + 4D}{R \times 100}$ $ADR \times 3 \times 4$ $A + 4D + \frac{3}{100}$

$A + 3D + \frac{4R}{100}$ $A + 3D + 4 \times 100 \times R$ $A + 2D + \frac{4R}{100}$

4. If all Poodles are curly and all Toys are Poodles, it follows that:

All curly dogs are poodles All curly Dogs are Toys Only Poodles are curly

All Toys are curly All Poodles are Toys

5. A wheel can turn at three rates. When turning slowest it produces X units/hour. At the medium speed it produces 2 times as many units/hour. At high speed it produces 4 times as many units per hour. If it runs for A hours at the slowest rate and B hours at medium and C hours at the fastest which equations show the total number of units produced.

- $AX + BX + CX$
 $\frac{X}{10} + \frac{2X}{B} + \frac{4X}{C}$
 $2AX + 4BX + CX$
- $AX + 2BX + 4CX$
 $A + 2B + 4C$

6. A bag holds A ballpoint pens: R pens are yellow, S are green, and T are black. Which equation represents the percentage of black pens?

- $\frac{100 - A}{R + ST}$
 $\frac{100(A - R + S)}{A}$
 $\frac{T}{R + ST + T - A}$
- $\frac{A - R + S}{A + R + S}$
 $\frac{100T}{A + T}$

7. Divide A by B. As B gets closer to 0, what does the result of the division of A by B get closer to?

- Zero
 A
 1
- $\frac{0}{A}$
 None of these

8. In a factory, a unit X composed of parts A and B, is produced. For every G part A pieces, H are defective. What percentage of X units are defective?

- $X(Z \times \frac{G}{H} + B)$
 $X \times + \frac{H}{G} + B$
 $A + B \times H$
- $\frac{100H}{G}$
 $\frac{100A - B}{X}$

End of Section 8: Go to Answer Key page 74

SECTION 10: ANSWER KEYS



Answer Key for Section: General Problem Solving Ability

Question	Answer	Question	Answer
1.	3	11.	2
2.	35	12.	20
3.	1	13.	17.22
4.	3	14.	5.25
5.	4	15.	2
6.	3	16.	20
7.	25¢	17.	3/32
8.	T	18.	1, 3
9.	3	19.	3
10.	10	20.	60¢

Standard Cut-offs

Mechanical Apprenticeship Candidates: To meet the basic standards for selection as a Mechanical Apprentice, you should be able to complete at least 9 of these questions correctly in the time allotted. The better you do, the more confident you could be of succeeding in the actual testing situation.

Electrical Apprenticeship Candidates: To meet the basic standards for selection as an Electrical Apprentice, you should be able to complete at least 10 of these questions correctly in the time allotted. The better you do, the more confident you could be of succeeding in the actual testing situation.

Development Suggestions:

To upgrade your problem solving skills, analyze what kind of questions you have the most trouble with – it could be verbal (such as questions 1 and 3), arithmetic (questions 7 and 14), spatial (questions 13), etc. Then practice those kinds of questions.

Answer Key for Section: Mechanical Reasoning

Question	Answer	Question	Answer
1.	B	6.	B
2.	B	7.	C
3.	B	8.	C
4.	A	9.	B
5.	A	10.	B

Standard Cut-Offs

Mechanical Apprenticeship Candidates: To meet the basic standards for selection as a Mechanical Apprentice, you should be able to complete at least 7 of these questions correctly in the time allotted. The better you do, the more confident you could be of succeeding in the actual testing situation.

Electrical Apprenticeship Candidates: To meet the basic standards for selection as a Mechanical Apprentice, you should be able to complete at least 7 of these questions correctly in the time allotted. The better you do, the more confident you could be of succeeding in the actual testing situation.

Development Suggestions:

Remedial high school science or physics courses will be helpful not only in passing this test but also will provide you with a solid foundation for an apprenticeship.

Explanations:

1. The correct answer is B. A key to answering this question is being able to visualize the direction of the rope. When you look at the pulley attached directly to the handle, pick a spot on the front of the rope. When the handle moves up (towards you) the front of the pulley moves up which, in turn, means the rope at the back must move in the opposite direction (down). Therefore, the weight will move down.
2. The correct answer is B. This question is based on the lever principle. The weight of the gate is supported by the guy wire attached to the top of the post and the bottom of the gate at the furthest point away from the main post.
3. The correct answer is B. When answering gear or pulley questions, always follow the principle of opposites – in other words, if the pulley moves up on one side, it must move down on the other. You can use a pencil to trace movement along the rope or belt attached to the pulley to get the direction correct.
4. The correct answer is A. The screw is a principle simple machine that converts rotational motion to linear motion. The pitch of the threads on the screw (course versus fine threads) determines the amount of torque (rotational force) needed to turn the screw. The courser the threads, the higher amount of torque are required to turn the screw. A key point on this question is ensuring that you read it carefully.
5. The correct answer is A. Milk is heavier than cream and therefore the cream would rise to the top of the milk.
6. The correct answer is B. In this case, the radio requires a functional ground connection in order to complete the circuit and receive signals. In a ground system the majority of electrons run

Appendix 1: Answer Keys

along the surface (or skin) of the conductor. A good RF ground has the least amount of resistance to electrons being conducted to ground. This is obtained by having the largest amount of conducting surface area that is practical. The goal of a good RF ground system is to obtain as little resistance as possible from the antenna/tower to ground and then from the radio to ground. Thus, the more conductor surface area the more ground path conductivity.

7. The correct answer is C. Both objects will be travelling at the same speed based on the principle of “terminal velocity.” An object falling on Earth will fall 9.81 meters per second faster every second (9.81 m/s^2). The reason an object reaches a terminal velocity is that the drag force resisting motion is directly proportional to the square of its speed. At low speeds, the drag is much less than the gravitational force and so the object accelerates. As it accelerates, the drag increases, until it equals the weight. Drag also depends on the projected area. This is why things with a large projected area, such as parachutes, have a lower terminal velocity than small objects such as cannon balls. Because these two objects are the same, they will both achieve terminal velocity before hitting the ground.
8. The correct answer is C. The principle of Static Fluid Pressure is that the pressure exerted by a static fluid depends only upon the depth of the fluid, the density of the fluid, and gravity. The fluid pressure at a given depth does not depend upon the total mass or volume of the liquid. Therefore, the pressure at the bottom of the dam would be the same at the same depth.
9. The correct answer is B. As you apply a downward pressure on the shelf, and move the support bracket closer to the wall, the less weight can be supported (think of the support bracket attached right at the wall).
10. The correct answer is B. The angular velocity is defined as the rate of change of position of an object and the axis about which the object is rotating. From the center point of the wheel, if you take a ruler and move it about the axis, Point B will move a greater distance than Point A from the axis. Therefore, must travel at a greater speed.

Answer Key for Section: Detail Checking Ability

Question	Answer	Question	Answer
1.	A	16.	B
2.	M	17.	B
3.	F	18.	F
4.	M	19.	M
5.	B	20.	H
6.	F	21.	H
7.	M	22.	A
8.	A	23.	F
9.	B	24.	B
10.	H	25.	H
11.	A	26.	F
12.	A	27.	H
13.	H	28.	F
14.	F	29.	M
15.	A	30.	B

Standard Cut-Offs

Mechanical Apprenticeship Candidates: To meet the basic standards for selection as a Mechanical Apprentice, you should be able to complete at least 14 of these questions correctly in the time allotted. The better you do, the more confident you could be of succeeding in the actual testing situation.

Electrical Apprenticeship Candidates: To meet the basic standards for selection as a Mechanical Apprentice, you should be able to complete at least 15 of these questions correctly in the time allotted. The better you do, the more confident you could be of succeeding in the actual testing situation.

Development Suggestions:

One of the key Essential Skills for the trades is Document Use. Further materials are available online. Do a Google search for “Essential Skills Document Use Trades” and you should be up to date materials.

Answer Key for Section: Arithmetic Reasoning

Questions 1 to 12						Questions 19 to 24					
	A	B	C	D	E		A	B	C	D	E
1.		X				19.		X			
2.	X					20.	X				
3.				X		21.			X		
4.					X	22.				X	
5.				X		23.	X				
6.				X		24.			X		
7.				X		Questions 25 to 30					
8.				X			A	B	C	D	E
9.			X			25.			X		
10.	X					26.			X		
11.				X		27.				X	
12.				X		28.					X
Questions 13 to 18						29.	X				
	A	B	C	D	E	30.				X	
13.				X		Questions 31 to 36					
14.		X					A	B	C	D	E
15.	X					31.					X
16.				X		32.					X
17.		X				33.			X		
18.			X			34.	X				
						35.			X		
						36.					X

Standard Cut-Offs

Mechanical Apprenticeship Candidates: To meet the basic standards for selection as a Mechanical Apprentice, you should be able to complete at least 17 of these questions correctly in the time allotted. The better you do, the more confident you could be of succeeding in the actual testing situation.

Electrical Apprenticeship Candidates: To meet the basic standards for selection as a Mechanical Apprentice, you should be able to complete at least 21 of these questions correctly in the time allotted. The better you do, the more confident you could be of succeeding in the actual testing situation.

Development Suggestions:

There are resources online to help you develop your skills.

Answer Key for Section: Judgment & Comprehension Test

Passage One

VFR, visual flight rules, govern flight under conditions of:

Acceptable visibility

Under IFR, control of the aircraft is dictated by:

The air traffic controller

VFR conditions vary from country to country and even locality to locality. Pilots learn about them from:

Aeronautical charts

Under VFR conditions, control of the airplane belongs to:

None of the above

The air traffic controller can identify each airplane on the screen by:

Its number, speed, altitude and course

Which of the following words might be used to describe the content of this passage:

Factual

Passage Two

A fact about Canadian business people is

That they:

Have not marketed their products internationally

Economic Analysts have stressed that because of technological revolutions and institutional changes:

One world market for goods and services has been created

For businesses to succeed, they must

All of the above

This author's style might be characterized as:

Expository

The best title for this passage would be:

Global Trade Competition

Passage Three

According to the author of this passage, democracy is the most viable form of government because:

It copes most efficiently with the changing demands of contemporary civilization.

In the last paragraph, according to the context of the sentence, the word pernicious likely means:

Exceedingly harmful

What condition(s) of a democratic nation does the author cite as proof of its effectiveness?

Duration of wealth and stability

The attitude of the author of this passage toward democracy seems to be basically one of:

Practical recommendation

A good title for this passage might be:

Why Democracy?

Standard Cut-offs

Mechanical Apprenticeship Candidates: To meet the basic standards for selection as a Mechanical Apprentice, you should be able to complete at least 9 of these questions correctly in the time allotted. The better you do, the more confident you could be of succeeding in the actual testing situation.

Electrical Apprenticeship Candidates: To meet the basic standards for selection as an Electrical Apprentice, you should be able to complete at least 10 of these questions correctly in the time allotted. The better you do, the more confident you could be of succeeding in the actual testing situation.

Answer Key for Section: Spatial Reasoning (Mechanical Trades Only)

Pictorial Drawing Letter	Matched Component Drawing Number
A	7
B	4
C	11
D	12
E	8
F	5
G	9
H	1
I	2
K	3
L	10
M	6
N	19
O	23
P	24
Q	20
R	18
S	14
T	16
U	13
V	22
W	15
X	17
Y	21

Standard Cut-Off:

To meet the basic standards for selection as a Mechanical Apprentice, you should be able to complete at least 9 of these questions correctly in the given time. The better you do, the more confident you could be of succeeding in the actual testing situation.

Answer Key for Section: Reasoning Using Mathematical Symbols (Electrical Trades Only)

Check your drawings against the patterns. They must be exact in order to be scored correct.

Standard Cut-Offs:

Electrical Apprenticeship Candidate: To meet the basic standards for selection as an Electrical Apprentice, you should be able to complete at least 4 of these questions correctly in the time allotted. The better you do, the more confident you could be of succeeding in the actual testing situation.

Question #	Answer
1	$D + B + 2P$
2	$\frac{E}{I}$
3	$A + 2D + \frac{4R}{100}$
4	All Toys are curly
5	$AX + 2BX + 4CX$
6	$\frac{100(A - R + S)}{A}$
7	None of these
8	$\frac{100H}{G}$

Standard Cut-Offs:

Electrical Apprenticeship Candidates: To meet the basic standards for selection as an Electrical Apprentice, you should be able to complete at least 3 of these questions correctly in the time allotted. The better you do, the more confident you could be in the actual testing situation.

Development Suggestions:

Individuals who do poorly on this test may find value in taking remedial high school mathematics and/or an algebra course.